

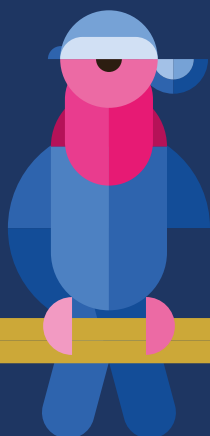

2023

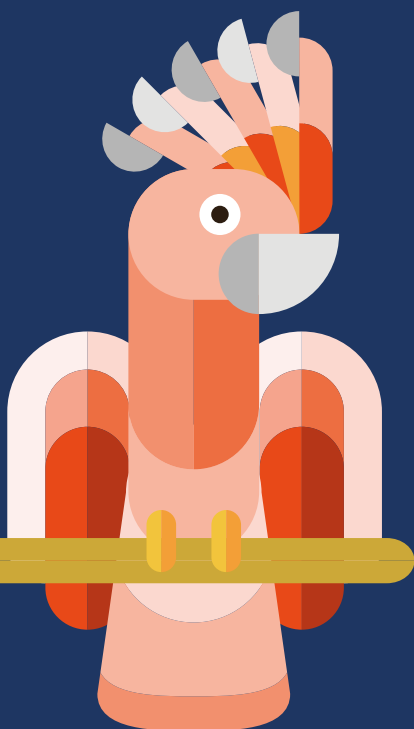
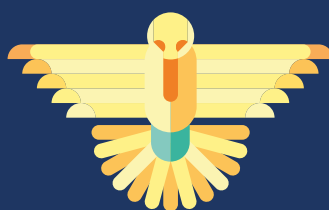

ACCESSORI PER ORNITOLOGIA E ANIMALI

Accessories for ornithology and animals
Accesorios por ornitología y animales
Accessoires pour l'ornithologie et animaux



STORIA DELL'AZIENDA

Partner affidabile con oltre 35 anni di esperienza. La 2GR nasce nel 1980 come azienda produttrice di stampi per materie plastiche, per conto terzi. Nel 1985 parallelamente all'attività di progettazione e costruzioni stampi, nasce la linea di prodotti per l'ornitologia che la 2GR inizia a produrre e commercializzare in proprio.

Fin da subito gli articoli 2GR spiccarono per qualità e facilità di montaggio e utilizzo, ma la scelta che si rivelò vincente, fu la ricerca di materiali assolutamente NON tossici. Le esigenze di mercato e la creatività dello staff tecnico consente di ampliare ed arricchire la gamma dei prodotti; il continuo confronto con gli allevatori ci consente un'attenzione progettuale e produttiva costante. Oggi la 2GR è presente in tanti mercati del mondo con oltre 400 prodotti per l'ornitologia, cane, gatto, tartarughe e criceti per il massimo confort dei nostri piccoli amici.

THE HISTORY OF THE FACTORY

Reliable partner for over 35 years. The 2GR was born on the 1980 as a factory producing moulds for plastic materials on behalf of a third party. In the 1985, together with the moulds' planning and producing activity, the 2GR creates its own ornitology range of products. The 2GR pays attention in choosing non toxic materials, high quality finishing, easy installation and use.

The market needs and the staff's creativity allow 2GR to enrich its range of products; the constant dialogue with breeders gives 2GR the possibility to pay attention to project making and constant production. Nowadays, 2GR is present in many markets around the world with over 400 products for ornitology, cats, dogs, turtle and hamsters and the maximum confort for our little friends.

HISTOIRE DE LA SOCIÉTÉ

Partenaire fiable avec plus de 35 années d'expérience. 2GR a été fondée en 1980 en tant que producteur de moules pour matériaux plastiques pour des tiers. En 1985, en parallèle à la conception et la fabrication de moules, vient la ligne de produits pour l'ornithologie que 2GR commence à produire et à commercialiser en propre.

La gamme de produits comprend une large gamme d'accessoires pour les oiseaux, comme des abreuvoirs, des mangeoires, des accessoires de transport, des baignoires et des nids; ainsi que des produits pour les petits animaux de compagnie comme les chiens et les chats, les tortues et les rongeurs, tels que des bols, des accessoires de transport, de la litière, des vivariums pour tortues et des cages pour hamsters. Depuis le début, les articles 2GR ont été appréciés pour leur qualité et leur facilité d'installation et d'utilisation, mais le choix qui a fait ses preuves a été la recherche de matériaux absolument non toxiques, une grande attention aux réglementations en vigueur concernant le transport des animaux, ce qui a amené 2GR à être le premier fabricant de produits de transport en plastique pour les oiseaux. Les exigences du marché et la créativité de l'équipe technique permettent d'élargir et d'enrichir la gamme de produits et le contact permanent avec les éleveurs nous permet d'assurer une attention constante dans la conception et la production. Aujourd'hui 2GR est présent sur de nombreux marchés dans le monde avec plus de 400 produits pour l'ornithologie, les chiens, les chats, les tortues et les hamsters pour assurer le confort maximum de nos petits amis.

HISTORIA DE LA EMPRESA

Un socio fiable mas 35 años. 2GR nace en el año 1980 como empresa especializada en la fabricación a terceros de models para inyección de materia plastica. En 1985, palalelamente a la actividad de proyectar y construir models, nace una linea de productos para la ornitologia.

La empresa 2GR comienza a producir y comercializar productos desde su propia estructura, utilizando materiales no tóxicos, acabados de calidad, praticos y faciles de montar y utilizar. Con la exigencia del mercado y la creatividad del equipo técnico logramos ampliar y enriquecer la gama de productos, así como la continua relación con los criadores logra que exista una atención y tension proyectiva y productiva constante. Al día de hoy, la empresa 2GR esta presente en muchos y diferentes mercados del mundo con mas de 400 productos especializados para ornitologia, perros, gatos, tortugas y roedores con el fin de ofrecer el maximo confort a nuestros pequeños amigos.





Trasportini 6
Transport
Transportin
Cage de transport

Beverini 23
Drinkers
Bevederos
Fontaines

Mangiatoie 32
Feeders
Comederos
Mangeoires

Bagni 47
Baths
Bañeras
Bains

Nidi 49
Nests
Nidos
Nids

Gabbie 61
Cages
Jaulas
Cages

Fondi 88
Bottoms
Fondos
Fonds

Accessori 58
Accessories
Accesorios
Accessoires



Uccelli
BIRDS / PÁJAROS / OISEAUX



TINO



TUTTI I NOSTRI ARTICOLI DA TRASPORTO
RISPETTANO LE NUOVE NORMATIVE

Art. 207



— cm. 38 x 39 x 3h
Coperchio con maniglia
Lid with handle
Tapa con asa
Couvercle avec poignée



INTERNO ESTRAIBILE



Art. 200



— cm. 38 x 39 x 18h
Trasportino con griglia fissa e mangiatoia esterna
Transport cage with fixed grill and external feeder
Trasportin con reja fija y comederos externos
Cage de transport avec grille fixe et mangeoires extérieures



TINO ECONOMY

Art. 235



— cm. 38 x 39 x 18h
Tino Economy senza interno estraibile
Tino Economy without internal grey case
Tino Economy sin caja interna gris
Tino Economy sans caisse interne grise



Art. 250



Interno completo dell'Art. 200
Interior complete of Art. 200
Interior completo para Art. 200
Interieur complet pour Art. 200



Art. 201



— cm. 38 x 39 x 18h

Trasportino con griglia fissa e mangiatoia interna

Transport cage with fixed grill and internal feeder
Trasportin con reja fija y comederos internos
Cage de transport avec grille fixe et mangeoires internes

TINO

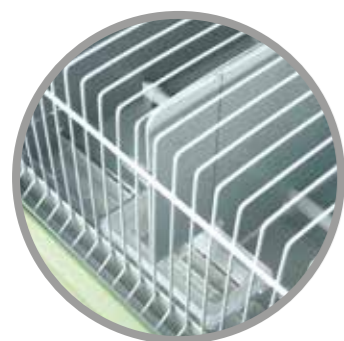

Art. 202



— cm. 38 x 39 x 18h -> 35h

Trasportino con griglia Telescopica

Transport cage with Telescopic grill
Trasportin con reja Telescópica
Cage de transport avec grille telescopique

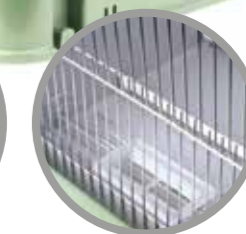

IDONEO PER MOSTRE SCAMBIO

Art. 251



Interno completo dell'Art. 201

Interior complete of Art. 201
Interior completo para Art. 201
Interieur complet pour Art. 201



Art. 218



Scatola esterna del Tino

Tino 's external case
Caja externa de Tino
Caisse externe du Tino



Art. 252



Interno completo dell'Art. 202

Interior complete of Art. 202
Interior completo para Art. 202
Interieur complet pour Art. 202



Art. 458



— cm. 66,8 x 34,3 x 21h -> 30h
Maxi tino con griglia Telescopica
Maxi tino con griglia Telescopica
Maxi tino with Telescopic grill
Maxi Tino con rejilla Telescópica
Maxi Tino avec grille telescopique

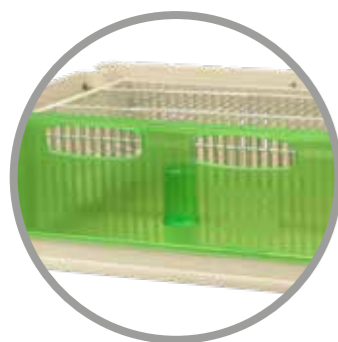
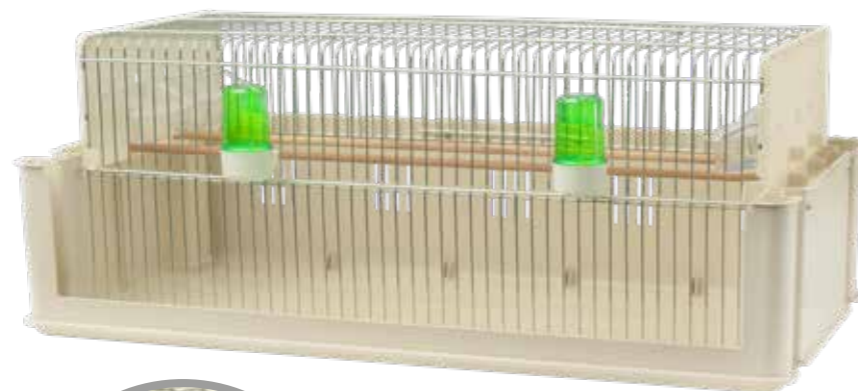

MAXI TINO
IDEALE PER MOSTRE SCAMBIO

Art. 217



— cm. 66,8 x 34,3 x 2,5h
Coperchio per Maxi-Tino
Maxi-Tino's cover
Tapa para Maxi-Tino
Couvercle pour Maxi-Tino



Art. 205



— cm. 66,8 x 34,3 x 21h
Trasportino per soggetti di media taglia aperto sul retro
Transport cage for medium sizes bird open in the back side
Transportin para parajos tamaños mediano abierto posteriormente
Cage de Transport pour oiseaux de moyenne taille ouverte à l'arrière

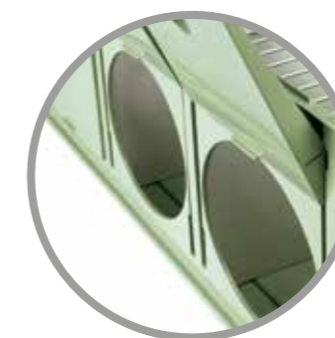

Art. 204



— cm. 66,8 x 34,3 x 21h
Trasportino per ondulati a 5 posti
Transport cage for budgerigar 5 spaces
Transportin para periquito a 5 lugares
Cage de transport pour perokeet avec 5 lieux



Art. 233



— cm. 66,8 x 34,3 x 21h
Trasportino per soggetti di media taglia chiuso sul retro
Transport cage for medium sizes bird closed in the back side
Transportin para parajos tamaños mediano cerrado posteriormente
Cage de Transport pour oiseaux de moyenne taille fermé à l'arrière



SECONDINO

Trasporto singolo / Single transport / Transporte singolo / Transport individuel

Art. 220



— cm. 16 x 11,7 x 14,6h

Trasporto singolo per taglie piccole

Single transport cage for small size

Transporte unico para tallas pequeñas

Cage de transport pour petites tailles



**TUTTI I NOSTRI ARTICOLI DA TRASPORTO
RISPETTANO LE NUOVE NORMATIVE**



Art. 203



— cm. 38 x 39 x 18h

Tino + n. 6 Secondino



Art. 234



— cm. 66,8 x 34,3 x 21h
Maxi Tino + n. 10 Secondini



Art. 239



cm. 66,8 x 34,3 x 21h
Maxi Tino vuoto con supporti
Maxi Tino empty with support
Maxi Tino vacío con soporte
Maxi Tino vide avec soutien



VALIGIA

Art. 225



— cm. 66,8 x 21 x 36h
Valigia completa di 10 Secondini
Complete case with 10 Secondini
Maleta con 10 Secondini
Valise complet avec 10 Secondini



Art. 226



— cm. 66,8 x 21 x 36h
Valigia vuota
Empty case
Maleta vacia
Valise vide



SECONDINO MEDIO

Trasporto singolo medio / Secondino Medium-size / Secondino Mediano / Secondino Moyen

Art. 244



— cm. 20 x 11 x 14 h.
Trasportino singolo per taglie medie
Single transport cage for medium size
Transporte singolo para talla media
Cage de transport pour tailles moyenne



Art. 256



— cm. 37 x 22 x 43h
Valigia 6 posti
Case with 6 places
Maleta con 6 lugares
Valise avec 6 lieux



Art. 261



Valigia vuota con 6 posti
Empty case with 6 places
Maleta vacia con 6 lugares
Valise vide avec 6 lieux



Art. 276



Copertura x valigia 6 posti
Cover for 6 places case
Cobertura para maleta con 6 lugares
Couverture pour valise avec 6 lieux



Art. 257



— cm. 48 x 22 x 43h

Valigia 8 posti

Case with 8 places
Maleta con 8 lugares
Valise avec 8 lieux



Art. 259



— cm. 71 x 22 x 62h

Valigia 18 posti

Case with 18 places
Maleta con 18 lugares
Valise avec 18 lieux



Art. 262



Valigia vuota 8 posti

Empty case with 8 places
Maleta vacia con 8 lugares
Valise vide avec 8 lieux



Art. 277



Copertura x valigia 8 posti

Cover for 8 places case
Cobertura para maleta con 8 lugares
Couverture pour valise avec 8 lieux



Art. 258



— cm. 71 x 22 x 43h

Valigia 12 posti

Case with 12 places
Maleta con 12 lugares
Valise avec 12 lieux



Art. 264



Valigia vuota 18 posti

Empty case with 18 places
Maleta vacia con 18 lugares
Valise vide avec 18 lieux



Art. 263



Valigia vuota 12 posti

Empty case with 12 places
Maleta vacia con 12 lugares
Valise vide avec 12 lieux



Art. 278



Copertura x valigia 12 posti

Cover for 12 places case
Cobertura para maleta con 12 lugares
Couverture pour valise avec 12 lieux



Art. 279



Copertura x valigia 18 posti

Cover for 18 places case
Cobertura para maleta con 18 lugares
Couverture pour valise avec 18 lieux



Art. 273



— cm. 75 x 45 x 110h
Carrello con 60 secondini medi
Trolley with 60 medium-size Secondini
Carrito con 60 Secondini medianos
Chariot avec 60 Secondini



Art. 273/A



— cm. 75 x 45 x 43h
Modulo superiore con 24 Secondini
Upper module with 24 Secondini
Modulo superior con 24 Secondini
Module supérieur avec 24 Secondini



Art. 273/B



— cm. 75 x 45 x 70h
Modulo inferiore con 36 Secondini
Lower module with 36 Secondini
Modulo inferior con 36 Secondini
Module basse avec 36 Secondini



Art. 273/C

— cm. 75 x 45 x 6h
Comp. trasformazione ruote removibili
Additional part for removable wheels
Componente para ruedas removible
Part supplémentaire pour roues amovibles



Art. 260



cm. 120 x 44 x 164h
Carrello con 160 secondini medi
Trolley with 160 medium-size Secondini
Carrito con 160 Secondini medianos
Chariot avec 160 Secondini

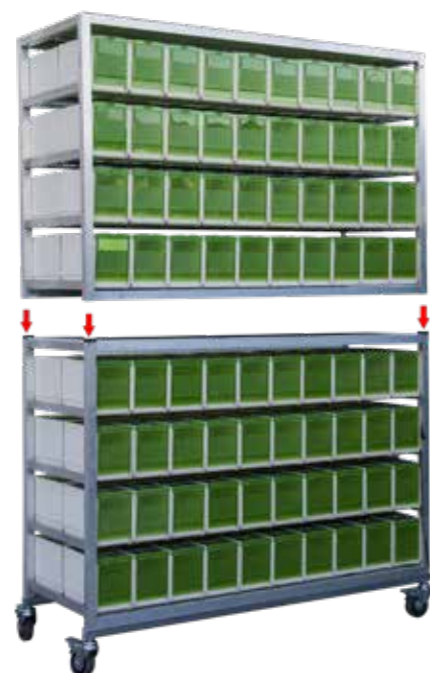

FORMATO DA DUE MODULI
MADE UP OF TWO MODULES
HECHO CON DOS MODULOS
FAIT AVEC DEUX MODULES

SECONDINO MAXI

Art. 242



— cm. 31 x 11,5 x 16h
Trasportino singolo per taglie grandi
Single transport cage for big size
Transporte singolo para talla grande
Cage de transport pour tailles grand



NO GRIGLIA SUL FONDO
NO GRILL ON THE BOTTOM



RISPETTA LE NUOVE NORMATIVE

Art. 245



— cm. 66,8 x 34,3 x 21h
Maxi Tino + n. 5 Secondini Maxi



Art. 214



— cm. 10 x 5 x 4h
Mangiatoia rettangolare
Rectangular feeder
Comedero rectangular
Mangeoire rectangulaire



Art. 206



cc. 100
Beverino rettangolare
Rectangular drinker
Bebedero rectangular
Fontaine rectangulaire



Art. 215



Parete estraibile per Tino
Tino's removable wall
Pared extraible para Tino
Amovible cloison pour Tino



Art. 227



Parete estraibile per Maxi-Tino
Maxi-Tino's removable wall
Pared extraible para Maxi-Tino
Amovible cloison pour Maxi-Tino



Art. 248



cc. 50
Beverino/Mangiatoia per art. 242 e 244
Drinker/Feeder for art. 242 and 244
Bebedero/Comedero para art. 242 y 244
Fontaine/Mangeoire pour art. 242 et 244



Art. 236



Divisoria per Tino Economy
Tino Economy's dividing wall
Divisoria para Tino Economy
Cloison pour Tino Economy

COMPATIBILE CON
ART. 235



Art. 209



Divisoria per Tino
Tino's Dividing wall
Divisoria para Tino
Cloison pour Tino

COMPATIBILE CON
ART. 200-201



Art. 247



Gancio per coperchio valigia art. 225
Hook for case's cover art. 225
Gancho para tapa maleta art. 225
Crochet pour couvercle de la valise art. 225



Art. 210



Gancio
Hook
Gancho
Crochet



Art. 228/C



Divisoria per Maxi-Tino
Maxi-Tino's dividing wall
Divisoria para Maxi-Tino
Cloison pour Maxi-Tino

PER MAXI TINO
SENZA POSATOI



Art. 228/A



Divisoria per Maxi-Tino
Maxi-Tino's dividing wall
Divisoria para Maxi-Tino
Cloison pour Maxi-Tino

COMPATIBILE CON
ART. 204-205-233



Art. 216



— cm. 29
Posatoio per Art. 200-201-202
Perch for Art. 200-201-202
Posaderos para Art. 200-201-202
Perchoir pour Art. 200-201-202



Art. 249



— cm. 35,5
Posatoio per Art. 235
Perch for Art. 235
Posaderos para Art. 235
Perchoir pour Art. 235



Art. 237



Supporti per Secondino
Supports for Secondino
Soportes para Secondino
Soutien pour Secondino



Art. 208



Ruote
Wheels
Ruedas
Roues



Art. 238



Griglia per Art. 235
Grill for Art. 235
Reja para Art. 235
Grille pour Art. 235

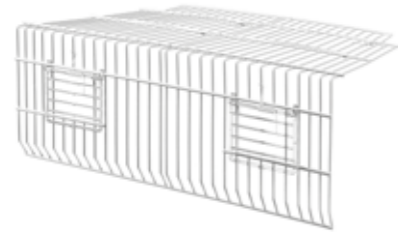

Art. 211



Griglia per Art. 200
Grill for Art. 200
Reja para Art. 200
Grille pour Art. 200



Art. 212



Griglia per Art. 201
Grill for Art. 201
Reja para Art. 201
Grille pour Art. 201

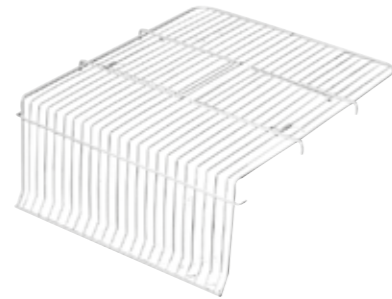

Art. 213



Griglia per Art. 202
Grill for Art. 202
Reja para Art. 202
Grille pour Art. 202



Art. 229



Griglia per art.204
Grill for art. 204
Reja para art. 204
Grille pour art. 204

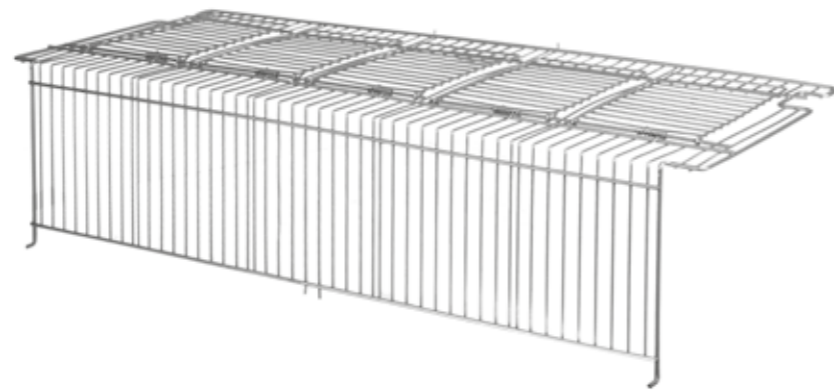

Art. 230



Griglia per art.205
Grill for art. 205
Reja para art. 205
Grille pour art. 205



Art. 146



cc. 40
Beverino per medicinali
Medicine dispenser
Bebedero para medicamentos
Fontaine pour médicaments

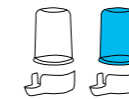

Art. 274



cc. 72
Sifone Aosta corto
Aosta short siphon
Bebedero corto Aosta
Fontaine court Aosta

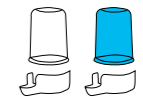

Art. 284



cc. 105
Sifone Aosta lungo
Aosta long siphon
Bebedero Aosta largo
Fontaine long Aosta

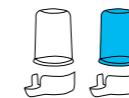

Art. 184



cc. 200
Sifone Leo
Leo siphon
Bebedero Leo
Fontaine Leo

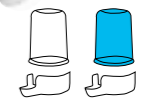

Art. 386



cc. 260
Sifone Venezia
Venezia Siphon
Bebedero Venezia
Fontaine Venezia



Art. 387



cc. 400
Sifone Pisa
Pisa Siphon
Bebedero Pisa
Fontaine Pisa





Art. 240



cc. 20
Beverino Dino
Dino drinker
Bebedero Dino
Fontaine Dino

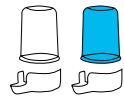

Art. 221



cc. 30
Beverino Secondino
Secondino drinker
Bebedero Secondino
Fontaine Secondino

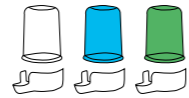

Art. 131



cc. 140
Sifone Marta
Marta siphon
Bebedero Marta
Fontaine Marta

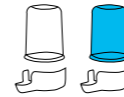

Art. 275



cc. 200
Sifone Ferrara
Ferrara siphon
Bebedero Ferrara
Fontaine Ferrara

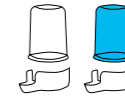

Art. 380



cc. 260
Sifone Amalfi
Amalfi siphon
Bebedero Amalfi
Fontaine Amalfi

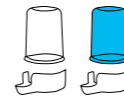

Art. 222



cc. 105
Sifone universale
Siphon universal
Bebedero universal
Fontaine Universel



Art. 158



cc. 72
Beverino corto lusso
Short luxury drinker
Bebedero corto lujo
Fontaine court luxe

NOVITA'

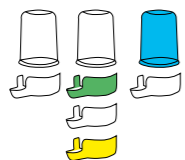

Art. 128



cc. 105
Beverino lungo lusso
Long luxury siphon
Bebedero largo lujo
Fontaine long luxe

NOVITA'

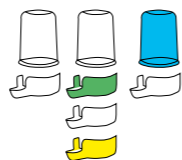

Art. 285



cc. 400
Sifone Livorno
Livorno siphon
Bebedero Livorno
Fontaine Livorno

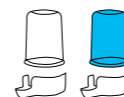

SERIE SENZA BORDO



SERIE SENZA BORDO



Art. 018/F



cc. 70
Beverino corto fumè
Short brown siphon
Bebedero corto fumé
Fontaine court fumé



Art. 018



cc. 70
Beverino corto
Short siphon
Bebedero corto
Fontaine court



Art. 068



cc. 260
Sifone Reggio
Reggio siphon
Bebedero Reggio
Fontaine Reggio



Art. 060/A



cc. 400
Sifone Lucca con anello
Lucca siphon with ring
Bebedero Lucca con anilla
Fontaine Lucca avec anneau



Art. 038



cc. 90
Sifone lungo
Long siphon
Bebedero largo
Fontaine long

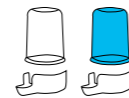

Art. 087



cc. 80
Sifone banana
Banana-shaped siphon
Bebedero banana
Fontaine banane

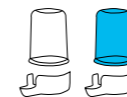

Art. 395



Anello per beverini cc 400
Ring for drinkers cc 400
Anilla para bebederos cc 400
Anneau pour abreuvoir cc 400



Art. 034



cc. 200
Sifone Firenze
Firenze siphon
Bebedero Florencia
Fontaine Florence



Art. 134



cc. 200
Sifone Firenze lusso
Firenze luxury siphon
Bebedero Florencia lujo
Fontaine Florence luxe



BEVERINO A GOCCIA - DROP DRINKER - BEBEDERO A GOTA - FONTAINE AVEC GOUTTE



BEVERINO CON SFERE
SIPHON WITH SPHERES
BEBEDERO CON BOLAS
FONTAINE AVEC SPHERE



BEVERINO SENZA SFERE
SIPHON WITHOUT SPHERES
BEBEDERO SIN BOLAS
FONTAINE SANS SPHERE

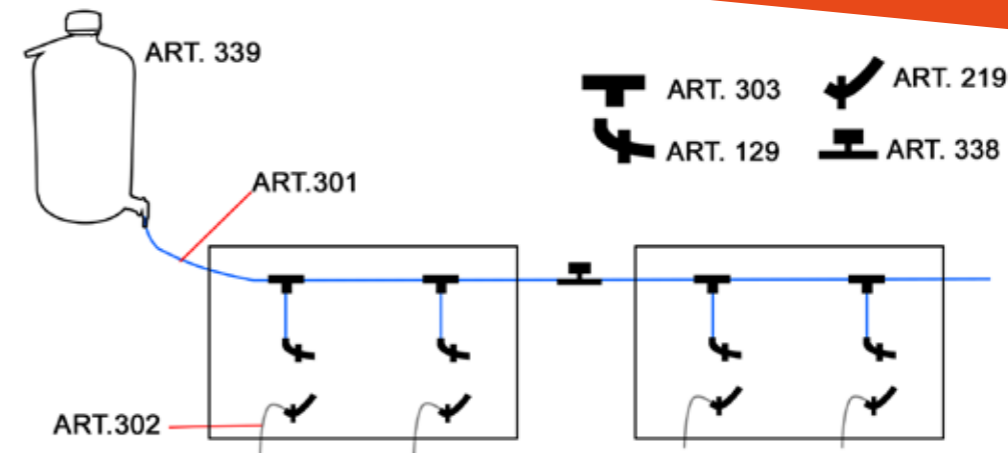

Art. 361



Sifone Revolution cc 72
Revolution siphon cc 72
Bebedero Revolution cc 72
Fontaine Revolution cc 72



Art. 362



Sifone Revolution cc 105
Revolution siphon cc 105
Bebedero Revolution cc 105
Fontaine Revolution cc 105



Art. 129



Erogatore magic
Magic dispenser
Dispensador magic
Distributeur Magique



Art. 219



Salva-goccia per Art. 129
Drop-saver for Art. 129
Salva-gota para Art. 129
Salve-goutte pour Art. 129



Art. 363



Sifone Revolution cc 140
Revolution siphon cc 140
Bebedero Revolution cc 140
Fontaine Revolution cc 140



Art. 364



Sifone Revolution cc 200
Revolution siphon cc 200 Bebe-
dero Revolution cc 200
Fontaine Revolution cc 200



Art. 301



Tubo diam. int. 5 per art. 129
Tube diameter int. 5 for art. 129
Tubo diámetro int. 5 para art. 129
Tube diámetro int. 5 pour art. 129



Art. 302



Tubo diam. int. 8 per art. 219
Tube diameter int. 8 for art. 219
Tubo diámetro int. 8 art. 219
Tube diámetro int. 8 pour art. 219



Art. 365



Sifone Revolution cc 260
Revolution siphon cc 260
Bebedero Revolution cc 260
Fontaine Revolution cc 260



Art. 366



Sifone Revolution cc 400
Revolution siphon cc 400
Bebedero Revolution cc 400
Fontaine Revolution cc 400



Art. 303



Raccordo a "T" per tubo art. 301
"T" Connection for tube art. 301
Conector "T" para tubo art. 301
Raccord "T" pour tube art. 301



Art. 338



Rubinetto per tubo art. 301
Tap for tube art. 301
Grifo para tubo art. 301
Robinet pour tube art. 301



Art. 339



Serbatoio per impianto a goccia
Tank for drop system
Tanque para sistema de gota
Réservoir pour système goutte



LT. 10

Art. 310



cc. 500 - cm. 9 x 9 x 10h
Beverino Capri
 Capri dispenser
 Bebedero Capri
 Fontaine Capri

Art. 170



cc. 500 - cm. 9 x 9 x 10h
Beverino Aves
 Aves dispenser
 Bebedero Aves
 Fontaine Aves

Art. 321



cc. 400
Sifone Bari
 Bari siphon
 Bebedero Bari
 Fontaine Bari

Art. 066



cc. 400
Sifone Napoli
 Napoli siphon
 Bebedero Napoles
 Fontaine Napoli

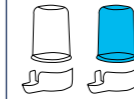

REGOLABILE

Art. 311



cc. 1000 - cm. 9 x 9 x 18h
Beverino Giglio
 Giglio dispenser
 Bebedero Giglio
 Fontaine Giglio

Art. 171



cc. 1000 - cm. 9 x 9 x 18h
Beverino Aves
 Aves dispenser
 Bebedero Aves
 Fontaine Aves

Art. 065



cc. 215
Sifone mang. pappagalli
 Feeder and siphon for parrot
 Comedero bebedero papagayo
 Siphon mangeoire perroquet

Art. 130



cc. 130
Beverino magic
 Magic drinker
 Bebedero magic
 Fontaine magique

Art. 253



— cm. 9 x 9 x 6,5h
Mangiatoia "Ara" piccola
 "Ara" small Feeder
 Comodero "Ara" pequeño
 Mangeoire "Ara" petit

Art. 254



— cm. 12 x 12 x 6,5h
Mangiatoia "Ara" media
 "Ara" medium Feeder
 Comodero "Ara" mediano
 Mangeoire "Ara" moyen



Art. 058



cc. 1500
Abbeveratoio per polli
Water dispenser for chicken
Abrevadero para pollitos
Abreuvoir pour poulet



Art. 186



— cm. 8 x 5
Porta
Door
Puerta
Porte

MOLLA NON INCLUSA
SPRING NOT INCLUDED

Art. 147



— cm. 8 x 4,5 x 7,5h
Mangiatoia "lusso"
"Lusso" feeder
Comedero "Lujo"
Mangeoire Luxe

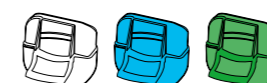

Art. 160



— cm. 8 x 4,5 x 7,5h
Mangiatoia Milano
Milano feeder
Comedero Milano
Mangeoire Milano

Art. 185



— cm. 7,5 x 5 x 8h
Mangiatoia Hasselt
Hasselt feeder
Comodero Hasselt
Mangeoire Hasselt

Art. 335



— cm. 7,3 x 8 x 7,5h
Mangiatoia Amsterdam
Amsterdam Feeder
Comedero Amsterdam
Mangeoire Amsterdam

Art. 024



— cm. 7 x 4 x 8h
Mangiatoia esterna
External feeder
Comedero externo
Mangeoire Exterieur

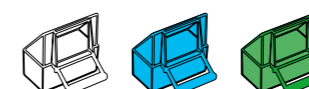

Art. 232



— cm. 7 x 4 x 8h
Mangiatoia interna con ganci
Internal feeder with hooks
Comedero interno con ganchos
Mangeoire interieur avec crochet

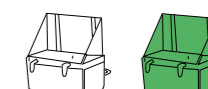

Art. 199



— cm. 7,5 x 5 x 8h
Mangiatoia Piacenza
Piacenza Feeder
Comodero Piacenza
Mangeoire Piacenza

Art. 017



— cm. 7 x 4 x 7h
Mangiatoia Napoli
Napoli feeder
Comedero Napoles
Mangeoire Napoli

Art. 103



— cm. 6,5 x 4 x 7,5h
Mangiatoia Spagna 2000
Spagna 2000 feeder
Comedero España 2000
Mangeoire Espagne 2000

Art. 105



— cm. 6,5 x 4 x 7,5h
Mangiatoia Italia 2000
Italia 2000 feeder
Comedero Italia 2000
Mangeoire Italia 2000





Art. 028



— cm. 6 x 4 x 5,3h
Mangiatoia mezzaluna
Half moon shaped feeder
Comedero media luna
Mangeoire demi-lune



Art. 035



— cm. 6 x 4 x 5,3h
Mangiatoia mezzaluna ganci
Half moon shaped feeder with hooks
Comedero media luna con gancho
Mangeoire demi-lune avec crochet



Art. 336



— cm. 6,4 x 4,5
Coperchio per mangiatoia mezzaluna
Cover for half moon shaped feeder
Tapa para comedero media luna
Couvercle pour mangeoire demi-lune



Art. 012



— cm. 6 x 3,4 x 3,2h
Mangiatoia att. dir. piccola
Small feeder with direct connection
Comedero pequeño enganchedirecto
Petit mangeoire connexion directe



Art. 013



— cm. 6 x 4 x 4,4h
Mangiatoia attacco diretto grande
Big feeder with direct connection
Comedero grande enganchedirecto
Mangeoire grand connexion directe



**MANGIATOIA COMPONIBILE
RECUPERA**

Art. 430
- cm. 12 x 11 x 16,5h
Mangiatoia Recupera
Recupera Feeder
Comedero Recupera
Mangeoire Recupera

170 Gr

BREVETTATO

6 PCS.



**DIMENSIONI DELLA PORTA MINIME:
MINIMUM DIMENSION OF THE DOOR:**

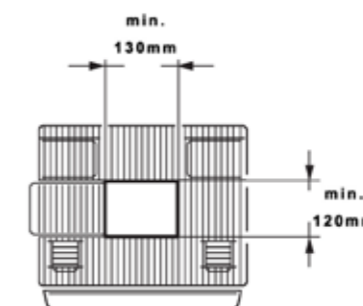

MANGIATOIA UNIKA

Art. 433

- cm. 8 x 10 x 13,5h
Mangiatoia Unika
Unika feeder
Comedero Unika
Mangeoire Unika

160 Gr



8 033844 764960

**ADATTA A TUTTI I TIPI DI PASTONCINI MORBIDI
E MANGIME COMPOSTO**

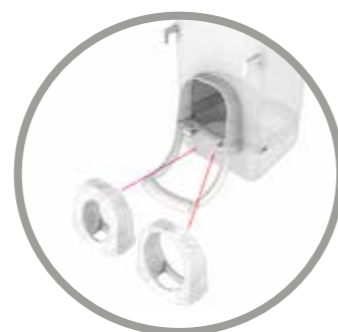

RIDUZIONI INCLUSE
REDUCTIONS INCLUDED

LA NUOVA MANGIATOIA ANTISPRECO RIVOLUZIONARIA
THE NEW REVOLUTIONARY NO-WASTE FEEDER
EL NUEVO COMEDERO REVOLUCIONARIO ANTI-DERROCE
LE NOUVEAU REVOLUTIONNAIRE MANGEOIRE ANTI-GASPILLAGE

Art. 323



8 033844 763796



- cm. 8 x 10 x 13,5h
Mangiatoia Eclissi
Eclipse feeder
Comedero Eclipse
Mangeoire Eclipse

KG. 0,240

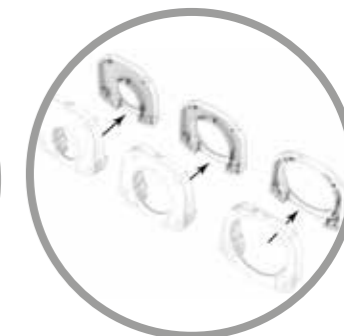
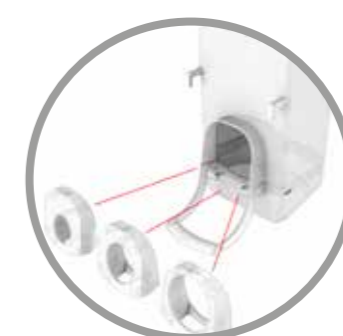

ADATTATORE 323/G GIÀ INCLUSO
ADAPTER 323/G INCLUDED
ADAPTADOR 323/G INCLUIDO
ADAPTATEUR 323/G INCLUS

SENZA PORTINA



PORTINA MONTATA AL CONTRARIO



PORTINA PIEGATA



Art. 323/G



Adattatore universale per Mangiatoia Eclissi
Universal adapter for Eclipse Feeder
Adaptador universal para comedero Eclipse
Adaptateur universel pour mangeoire Eclipse

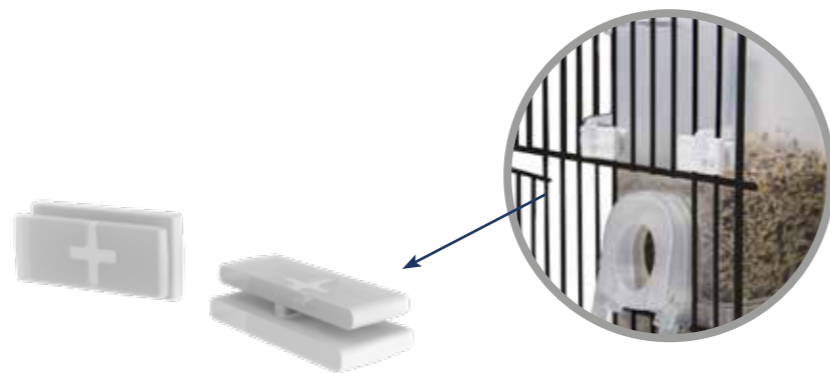

Art. 323/I



Supporti per attacco interno gabbia per Mangiatoia Eclissi
Cage's internal attachment for Eclipse Feeder
Suporte para ataque interno jaula para comedero Eclipse
Soutien d'attaque a l'interieure cage pour mangeoire Eclipse



Art. 117



- cm. 14 x 10 x 18h
Mangiatoia economy plus
Economy plus feeder
Comedero economy plus
Mangeoire economique plus



KG. 1

Art. 169



- cm. 10 x 9 x 15,5h
Mangiatoia economy Diamant
Diamant economy feeder
Comedero economy Diamant
Mangeoire economique Diamant



KG. 0,250

Art. 155



- cm. 14 x 10 x 21h
Mangiatoia economy dispenser
Economy feeder dispenser
Comedero economy dispenser
Mangeoire economique dispenser



KG. 1

Art. 115



- cm. 8 x 7 x 16h
Mangiatoia economy
Economy feeder
Comedero economy
Mangeoire economique

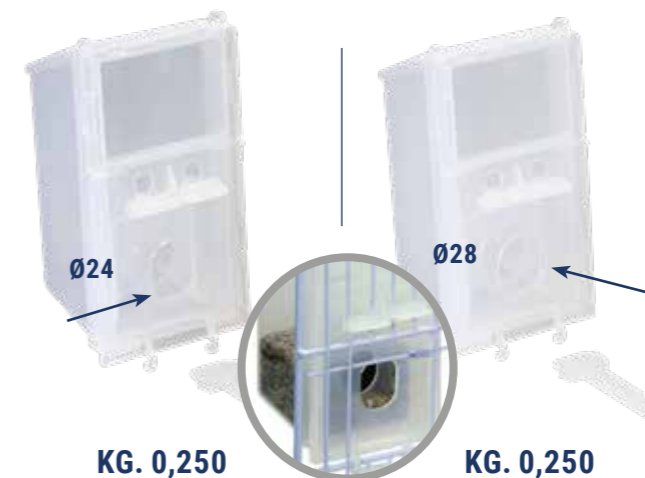

KG. 0,250

KG. 0,250

Art. 115/A



- cm. 8 x 7 x 16h
Mangiatoia economy
Economy feeder
Comedero economy
Mangeoire economique

Art. 116



- cm. 8 x 7 x 16h
Mangiatoia economy
Economy feeder
Comedero economy
Mangeoire economique

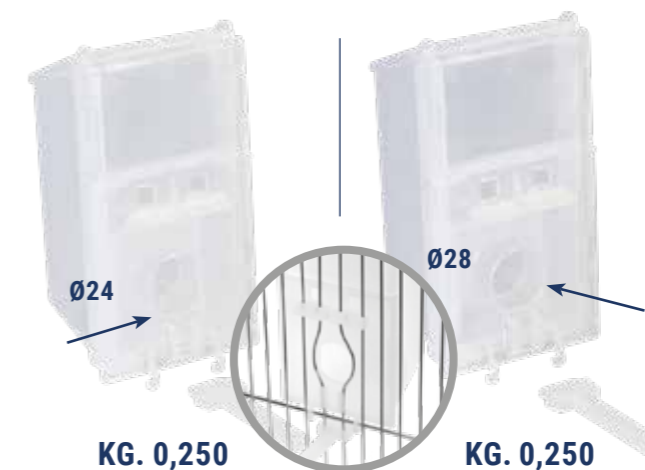

KG. 0,250

KG. 0,250

Art. 116/A



- cm. 8 x 7 x 16h
Mangiatoia economy
Economy feeder
Comedero economy
Mangeoire economique

Art. 022



— cm. 8 x 4 x 3h
Mangiatoia piccola c/ferri
Small feeder with irons
Comedero pequeño con gancho
Mangeoire petit avec crochet



Art. 022/G



— cm. 8 x 4 x 3h
Mang. piccola c/ferri con griglia
Small feeder with irons and grid
Comedero pequeño c/alambres y huella
Mangeoire petit avec crochet et grille



Art. 125



— cm. 8 x 4 x 3h
Mangiatoia piccola g/plastica
Small feeder with plastic hooks
Comedero pequeño con ganchos plastico
Mangeoire petit avec crochet de plastique



Art. 045



— cm. 10,5 x 5 x 3,5h
Mangiatoia media c/ferri
Medium feeder with irons
Comedero mediano con alambres
Moyenne mangeoire avec fers



Art. 053



— cm. 9 x 5 x 4,4h
Mangiatoia Parma
Parma feeder
Comedero Parma
Mangeoire Parma



Art. 054



— cm. 9 x 5 x 4,4h
Mangiatoia Parma c/ferri
Parma feeder with irons
Comedero Parma con alambres
Mangeoire Parma avec crochet en fer



Art. 173



— cm. 10,5 x 5,5 x 5h
Mangiatoia Dalia
Dalia feeder
Comedero Dalia
Mangeoire Dalia



ORA CON GRIGLIA!

Art. 172



— cm. 10,5 x 5,5 x 5h
Mangiatoia Ines
Ines feeder
Comedero Ines
Mangeoire Ines



Art. 127



— cm. 9 x 7 x 6,5h
Mangiatoia pappagallo g/plastica
Parrot feeder with plastic hooks
Comedero papagayo con ganchos plastico
Mangeoire perroquet avec crochet de plastique



Art. 015



— cm. 9 x 7 x 6,5h
Mangiatoia pappagallo c/ferri
Parrot feeder with irons
Comedero papagayo con alambres
Mangeoire perroquet avec crochet



Art. 043



— cm. 10 x 4,5 x 3h
Mangiatoia pappagallo con alette
Parrot feeder with wings
Comedero para papagayo con alas
Mangeoire pour perroquet avec ailes



Art. 313



— cm. 7,5 x 5,5 x 4h
Mangiatoia Olanda c/ganci plastica
Netherlands Feeder w/plastic hooks
Comedero Holanda c/ganchos plastico
Mangeoire Hollande avec crochet plastique

Art. 320



— cm. 7,5 x 5,5 x 0,5h
Antispreco per art. 313/314
Non-waste cover for art. 313/314
Anti-derroche art. 313/314
Anti-gaspillage art. 313/314

Art. 025/G



— cm. 20 x 6 x 4h
Mangiatoia universale con griglia
Universal feeder with grid
Comedero universal con rejilla
Mangeoire universel avec grille

Art. 314



— cm. 7,5 x 5,5 x 4h
Mangiatoia Olanda c/ganci in ferro
Netherlands Feeder w/iron hooks
Comedero Holanda c/ganchos hierro
Mangeoire Hollande avec crochet de fer

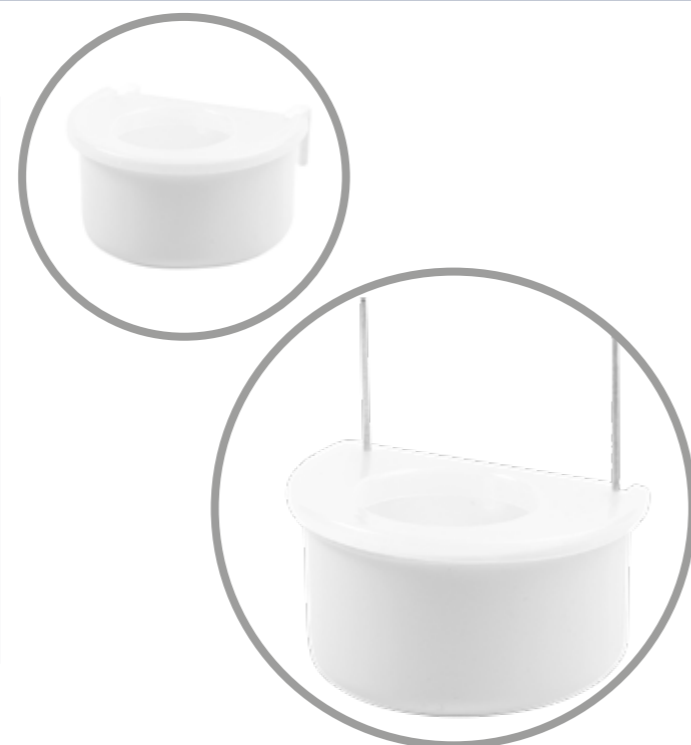
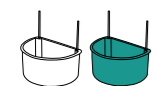

Art. 051



— cm. 30 x 5,5 x 4h
Mangiatoia Reggio
Reggio feeder
Comedero Reggio
Mangeoire Reggio

Art. 052



— cm. 30 x 5,5 x 4h
Mangiatoia Reggio c/ferri
Reggio feeder with irons
Comedero Reggio con alambres
Mangeoire Reggio avec crochet

Art. 324



— cm. 7 x 7 x 3h
Mangiatoia per svezzamento
Weaning feeder
Comedero para destete
Mangeoire pour sevrage

Art. 003



— cm. 18 x 4 x 3h
Mangiatoia ganci plastica
Feeders with plastic hooks
Comedero gancho plastico
Mangeoire avec crochet plastique

Art. 100



— cm. 39 x 5,5 x 6,5h
Mangiatoia per voliera trasparente c/ferri
Transparent aviary feeder with irons
Comedero transp. para voladora con alambre
Mangeoire transparent pour voliere



Art. 101

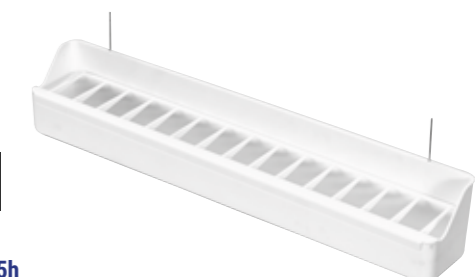

— cm. 39 x 5,5 x 6,5h
Mangiatoia per voliera bianca c/f
White aviary feeder with irons
Comedero bianco para voladora con alambre
Mangeoire blanc pour voliere avec crochet



Art. 099



— cm. 39 x 5,5 x 6,5h
Mangiatoia per voliera trasparente
Transparent aviary feeder
Comedero transp. para voladora
Mangeoire transparent pour voliere



Art. 098



— cm. 39 x 5,5 x 6,5h
Mangiatoia per voliera bianca
White aviary feeder
Comedero blanco para voladora
Mangeoire blanc pour voliere



Art. 071



ø cm. 7 x 3,5h
Mangiatoia girasole
Sunflower feeder
Comedero Girasol
Mangeoire Tournesol



Art. 073



ø cm. 7 x 3,5h
Mangiatoia girasole c/base
Sunflower feeder with base
Comedero Girasol con base
Mangeoire Tournesol avec base



Art. 255



— cm. 39 x 5,5 x 6,5h
Mangiatoia multipla
Multiple feeder
Comedero múltiples
Mangeoire Multiple



Art. 072



— cm. 7 x 12 x 3,5h
Mangiatoia ovale
Oval feeder
Comedero Ovalado
Mangeoire Ovale



Art. 119



— cm. 7 x 12 x 3,5h
Mangiatoia Titti
Titti feeder
Comedero Titti
Mangeoire Titti



Art. 190



— cm. 23 x 7 x 7,5h
Mangiatoia Toledo
Toledo Feeder
Comedero Toledo
Mangeoire Toledo



Art. 094



ø cm. 4,5 x 3,5h
Portapastoncino lusso
Luxury mash feeder
Portapasta lujo
Port pâtée



Art. 094/A



ø cm. 4,5 x 4,6h
Portapastoncino lusso alto
Luxury high mash feeder
Portapasta lujo alto
Port pâtée luxe haut



Art. 005



— cm. 31 x 14 x 15h
Mangiatoia colombi griglia plastica
Pigeon feeder plastic grid
Comedero paloma rejilla plastico
Mangeoire pigeons a/grille de plastique



Art. 006



— cm. 31 x 14 x 13h
Mangiatoia colombi griglia ferro
Pigeon feeder iron grid
Comedero paloma rejilla hierro
Mangeoire Pigeons a/grille de fer



Art. 322



ø cm. 2,5 x 2,7 h
Porta Sali Valencia
Cup for salt Valencia
Porta sales Valencia
Port sels Valencia



Art. 041



ø cm. 3,5 x 3h
Portasali
Cup for salt
Portasales
Port Sels



Art. 069



— **cm.4 x 3,5h**
Portauovo
 Egg holder
 Portahuevo
 Port Oeuf

Art. 070



— **cm. 9 x 6 x 2h**
Portabiscotto
 Biscuit holder
 Portabizcocho
 Port Biscuit

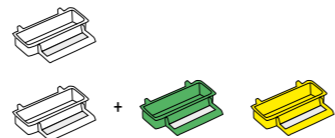

Art. 049



— **cm. 13 x 11 x 13h**
Bagno Reggio
 Reggio bath
 Bañera Reggio
 Baignoire Reggio

Art. 057



— **cm. 6 x 2 x 2h**
Portamedicinali
 Medicine dispenser
 Porta medicamentos
 Port medicament

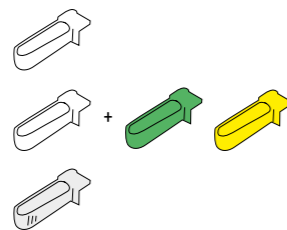

Art. 122



— **cm.7,5 x 3 x 6h**
Porta verdura e juta
 Vegetables/jute holder
 Porta verdura y portajuta
 Port legume et Jute

Art. 318



— **cm. 13 x 11 x 13h**
Bagno Esterno con ganci in plastica
 External Bath with plastic hooks
 Bañera Externa con ganchos en plastica
 Baignoire exterieur avec crochet en plastique

Art. 440



— **cm. 8 x 2 x 1,8h**
Portamedicinali Vitality
 Medicine dispenser Vitality
 Porta Medicamentos Vitality
 Port medicament Vitality

FACILE DA PULIRE!
EASY TO CLEAN!

Art. 142



cm. 5 x 3 x 1,5h
Pinza universale
 Universal holder
 Pinza universal
 Pince Universel



Art. 007



cm. 7 x 3 x 1,5h
Molletta gancio
 Peg hook
 Pinza sujetaverduras
 plastico
 Pince-crochet



Art. 046



— **cm. 13 x 8 x 4h**
Vaschetta bagno interna
 Internal bathtub
 Bañera interna
 Baignoire interieur

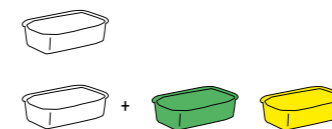

Art. 074



— **cm. 13 x 13 x 13h**
Bagno esterno lux
 Lux external bath
 Bañera externa lujo
 Baignoire exterieur luxe

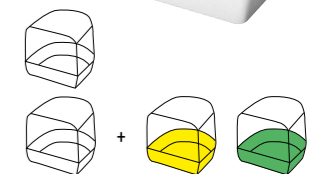

Art. 033



Portaseppia g/plastica
 Sepie holder with plastic hooks
 Portasepia con ganchos plastico
 Port Seiche avec crochet

Art. 082



Portaseppia
 Sepie holder
 Portasepia
 Port Seiche

Art. 435



— **cm. 11 x 11 x 12h**
Bagno esterno Garda
 External Bath Garda
 Bañera externa Garda
 Baignoire exterieur Garda



Art.441W



— cm. 24 x 18 x 16h
Bagno esterno Braies
 External Bathtub Braies
 Bañera externa Braies
 Baignoire exterieur Braies



FONDO BIANCO
 WHITE BOTTOM

Art.441T



— cm. 24 x 18 x 16h
Bagno esterno Braies
 External Bathtub Braies
 Bañera externa Braies
 Baignoire exterieur Braies



FONDO TRASPARENTE
 CLEAR BOTTOM

Art. 438W



— cm. 24 x 17 x 18h
Bagno esterno Como
 External Bathtub Como
 Bañera externa Como
 Baignoire exterieur Como



Art. 438B



— cm. 24 x 17 x 18h
Bagno esterno Como
 External Bathtub Como
 Bañera externa Como
 Baignoire exterieur Como



Art. 223



— cm. 12,5 x 18 x 16,5h
Nido per cardinalini ø 8
 Nest for Cardinals ø 8
 Nido para Cardenales ø 8
 Nid pour Cardinal ø 8



CIOTOLA NIDO ESTRAIBILE

Ø8

Art. 181



— cm. 12,5 x 18 x 16,5h
Nido Samsara ø 10
 Samsara nest ø 10
 Nido Samsara ø 10
 Nid Samsara ø 10



Ø10

Art. 437



— cm. 11 x 12 x 14,5h
Nido Easy
 Easy nest
 Nido Easy
 Nid Easy



**DISPONIBILE
 PROSSIMAMENTE
 COMING SOON**

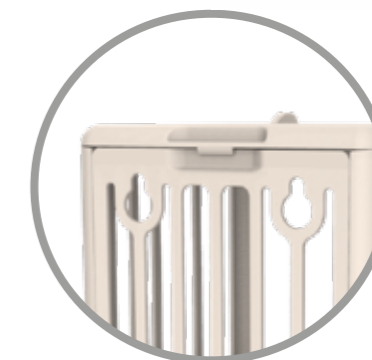
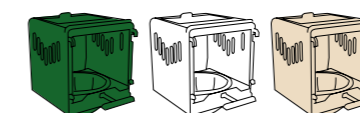

Art. 379



Scheda cova per nido art. 181/223/59/374
 Breeding cage for nest art. 181/223/59/374
 Tarjeta cova para nido art. 181/223/59/374
 Carte couvées pour nid art. 181/223/59/374



Art. 059



— cm. 12 x 12 x 17h
Nido esterno lusso
 External luxury nest
 Nido externo lujo
 Nid extérieur luxe

Ø10

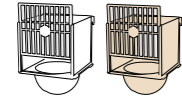

Art. 059/V



— cm. 12 x 12 x 17h
Nido esterno lusso
 External luxury nest
 Nido externo lujo
 Nid extérieur luxe

Ø10

Art. 376



Nido interno in plastica Relax
 Internal plastic nest Relax
 Nido interno en plástico Relax
 Nid intérieur en plastique Relax

Ø10

Art. 056



— cm. 10 x 11 x 16h
Nido esterno ferro/plastica
 Iron/plastic external nest
 Nido externo hierro y plástico
 Nid externe fer/plastique

Ø10

Art. 039



Nido interno
 Internal nest
 Nido interno
 Nid interne

Ø10

Art. 382

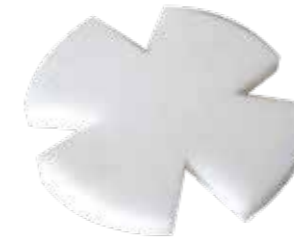

Fondello in gommapiuma
 Foam-rubber pad
 Fondo para nido en gomaespuma
 Fond nid en mousse

Ø12

Art. 381



Nido in gommapiuma
 Foam-rubber nest
 Nido de gomaespuma
 Nid en mousse

Ø10

Art. 008



Nido piccolo
 Small nest
 Nido pequeño
 Petit nid

Ø9

Art. 325



Nido Medio
 Medium Nest
 Nido mediano
 Nid moyen

Ø11

Art. 026



Portanido in ferro
 Iron nest holder
 Portanido hierro
 Porte nid en fer

Ø10

Art. 182



Ciotola nido
 Nest cup
 Cazoleta nido
 Bol nid

Ø10



Art. 009



Nido grande
 Large nest
 Nido grande
 Grand nid

Ø12

Art. 394



Portanido in ferro
 Iron nest holder
 Portanido hierro
 Porte nid en fer

Ø8

Art. 224



Ciotola nido
 Nest bowl
 Cazoleta nido
 Bol nid

Ø8



- PERFETTO PER:
- ONDULATO
 - NEOPSEPHOTUS
 - AGAPORNIS
 - PSEPHOTUS



FORO Ø 6 CM

NIDO PARADISE

Art. 374

— cm. 19,5 x 25 x 27,5h
Nido Paradise
 Paradise Nest
 Nido Paradise
 Nid Paradise



COMPATIBILE CON TUTTI I TIPI DI PORTA
 COMPATIBLE WITH ALL DOORS TYPE



FORO Ø 5 CM



CON SUPPORTO PER ONDULATI WITH NEST SUPPORT FOR BUDGIER



SENZA SUPPORTO PER AGAPORNIS / WITHOUT NEST SUPPORT FOR AGAPORNIS



PORTA SCHEDA SUL RETRO

COMPLETAMENTE IN PLASTICA - SMONTABILE E LAVABILE
 MADE IN PLASTIC - DISMOUNTABLE AND WASHABLE
 HECHO EN PLASTICO - DESMONTABLE Y LAVABLE
 FABRIQUE EN PLASTIQUE - DEMONTABLE ET LAVABLE

NIDO AGAPORNIS

Art. 427

— cm. 16,5 x 20 x 20h
Nido Agapornis
 Agapornis Nest
 Nido Agapornis
 Nid Agapornis



NIDO PER ONDULATI E PSITACCI DI PICCOLA TAGLIA



CON SUPPORTO PER ONDULATI WITH NEST SUPPORT FOR BUDGIER



SENZA SUPPORTO PER AGAPORNIS / WITHOUT NEST SUPPORT FOR AGAPORNIS



PORTA SCHEDA SUL RETRO

Art.427T

Coperchio per foro nido Agapornis
 Hole's cover for nest Agapornis
 Couvercle pour trou de nid Agapornis
 Tapa para agujero nido Agapornis



Art. 432



— cm. 13 x 10 x 10h
Nido per esotico
 Nest for exotic birds
 Nido exotico
 Nid exotique



Art. 432/G



Ganci per nido esotico
 Hooks for exotic nest
 Ganchos para nido exotico
 Crochet pour nid exotique



Art. 299



Nido goccia in vimini
 Drop wicker nest
 Nido gotas en mimbre
 Nid goutte en osier



Art. 293



Fondello Nido in Poliestere d. 10
 Polyester nest d. 10
 Fondo para nido en poliester d. 10
 Fond nid polyester d. 10



Art. 084



— cm. 12 x 13 x 16h
Nido diamante
 Diamond nest
 Nido diamante
 Nid Diamant



Art. 083



— cm. 12 x 13 x 16h
Nido perla
 Pearl nest
 Nido perla
 Nid Perle



Art. 291



Fondello Nido in juta d. 8 / 10 / 12
 Bird nest pad in juta d. 8 / 10 / 12
 Fondo para nido en yute d. 8 / 10 / 12
 Fond nid en jute d. 8 / 10 / 12



Art. 292



Fondello Nido in juta - cotone d. 8 / 10 / 12
 Wicker and pad bird nest d. 8 / 10 / 12
 Fondo para nido en yute y mimbre d. 8 / 10 / 12
 Fond nid en jute et coton d. 8 / 10 / 12



Art. 290/8



Fondello Nido in vimini
 Wicker bird nest
 Fondo para nido en mimbre
 Fond nid osier

Ø8

Art. 290/9



Fondello Nido in vimini
 Wicker bird nest
 Fondo para nido en mimbre
 Fond nid osier

Ø9

Art. 290/10



Fondello Nido in vimini
 Wicker bird nest
 Fondo para nido en mimbre
 Fond nid osier

Ø10

Art. 290/11



Fondello Nido in vimini
 Wicker bird nest
 Fondo para nido en mimbre
 Fond nid osier

Ø11

Art. 290/12



Fondello Nido in vimini
 Wicker bird nest
 Fondo para nido en mimbre
 Fond nid osier

Ø12

Art. 290/15

Ø15



Fondello Nido in vimini
 Wicker bird nest
 Fondo para nido en mimbre
 Fond nid osier

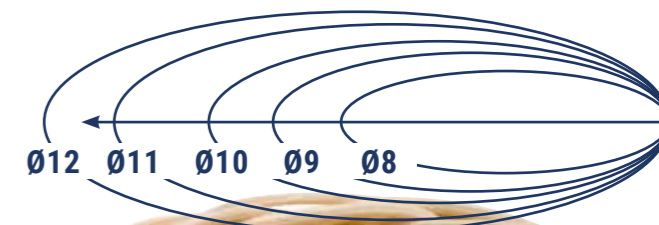

Art. 118



ø 7,5 x 7h
Porta Juta
 Nesting material holder
 Porta Juta
 Ramasseur de Jute

Art. 118/P



Porta Juta pieno
 Holder with jute
 Porta Juta con jute
 Ramasseur de Jute plein

Art. 097



– cm. 6 x 8 X 4h
Raccogliore universale
 Multi purpose holder
 Portapelo universal
 Ramasseur Universel

Art. 097/P



Raccogliore juta pieno
 Jute holder full
 Porta-Juta lleno
 Ramasseur de Jute plein

Art. 294

Confezione di Juta
 Jute's packaging
 Confeccion de Yute
 Confection de Jute



Art. 296

Confezione di Filo di Cotone
 Cotton's packaging
 Confeccion de Hilo de coton
 Confection de Fil de coton



Art. 297

Cocco-Sisal-Juta-Cotone
 Cocco-Sisal-Jute-Cotton
 Cocco-Sisal-Yute-Coton
 Coque-Sisal-Jute-Coton



Art. 295

Juta-Cotone
 Jute-Cotton
 Yute-Coton
 Jute-Coton



Art. 298

Cocco-Sisal-Meliga-Brattea



Art. 384



– cm. 12,5 x 10,5 x1 ,2 h
Portascheda Twister
 Card holder "Twister"
 Portatarjeta "Twister"
 Porte-carte "Twister"



IL NUOVO PORTA SCHEDA RIVOLUZIONARIO!
 NEW REVOLUTIONARY CARD HOLDER!
 EL NUEVO PORTA TARJETA REVOLUCIONARIO!
 LE NOUVEAU PORTE-CARTE REVOLUTIONNAIRE!

Art. 001/A



– cm. 12,5 x 9
Scheda a 4 cove
 Card for 4 broods
 Tarjeta para 4 covas
 Carte pour 4 couvées



Art. 385



– ø 4
Schedina Twister
 "Twister" Card
 Tarjeta "Twister"
 Carte "Twister"



ACCESSORI INCLUSI / ACCESSORIES INCLUDED



Art. 306/MONO



Anelli in plastica monocolore d. 2,8 mm
 Monochrome plastic rings d. 2,8 mm
 Anillas en plástico mono color d. 2,8 mm
 Anneaux de plastique monochrome 2,8 mm

Art. 306/MIX



Anelli in plastica multicolore d. 2,8 mm
 Multicolored plastic rings d. 2,8 mm
 Anillas en plástico multicolor d. 2,8 mm
 Anneaux de plastique multicolor 2,8 mm

Art. 307

8

12

16



Anelli "click" in plastica d. 8 / 12 / 16
 Plastic "click" rings d. 8 / 12 / 16
 Anillas abierta en plastica d. 8 / 12 / 16
 Anneaux de plastique d. 8 / 12 / 16



Art. 308



2,5



3



4



Anelli in alluminio d. 2,5 / 3 / 4
 Aluminium rings d. 2,5 / 3 / 4
 Anillas en aluminio d. 2,5 / 3 / 4
 Anneaux de aluminium d. 2,5 / 3 / 4

Art. 308



6
10



8
12



Anelli in alluminio d. 6 / 8 / 10 / 12
 Aluminium rings d. 6 / 8 / 10 / 12
 Anillas en aluminio d. 6 / 8 / 10 / 12
 Anneaux de aluminium d. 6 / 8 / 10 / 12

Art. 309



Tronchese inox per anellini
 Stainless steel nippers for rings
 Tijeras en acero para anillitas
 Cutter pour anneaux

Art. 078



— cm. 15 x 3 x 1h
Pinza Reggio
 Reggio pliers
 Pinza Reggio
 Pince Reggio

Art. 010



ø 1,3 x 1,6h
Uova piccole
 Small eggs
 Huevo pequeño
 Petit Oeufs

Art. 010/C



ø 1,3 x 1,6h
Uova piccole colorate
 Small coloured eggs
 Huevo pequeño azul-verde
 Petit Oeufs de couleur

Art. 011



ø 3 x 4h
Uova per colombi
 Pigeons eggs
 Huevos para palomas
 Oeufs pour pigeons

Art. 304



ø 2 x 2,5h
Uova medio Parrocchetto
 Medium plastic eggs for parakeets
 Huevos medianos para pericos
 Moyen Oeufs pour perroquet

Art. 305



ø 2,5 x 3h
Uova grandi Parrocchetto
 Big plastic eggs for parakeets
 Huevos grandes para pericos
 Grand Oeufs pour perroquet



Art. 036



— **cm. 29,5 x 32 x 1**
Laterale in plastica per gabbia cova 55
Plastic side for breeding cage 55
Lateral en plastico para jaula de cria 55
Lateral en plastique pour cage d'élevage 55

Art. 037/A



— **cm. 54,5 x 6 x 0,5**
Bandina frontale gabbia cova 55
Drawer's cover for breeding cage 55
Frontal para bandeja jaula de cria 55
Couvercle du tiroir pour cage d'élevage 55

Art. 064



— **cm. 54,2 x 30 x 4**
Fondo gabbia cova 55
Bottom part of breeding cage 55
Bandeja para jaula de cria 55
Tiroir pour cage d'élevage 55

GABBIA COVA 58x30 CM
LATERALI IN FERRO

Art. 317/B



3 PORTE GRANDI

cm. 58 x 30 x 39h
Gabbia cova plastificata
Plastified breeding cage
Jaula de cria plastificada
Cage de élevage plastifiée

Art. 317/Z



3 PORTE GRANDI

cm. 58 x 30 x 39h
Gabbia cova zincata
Breeding galvanized cage
Jaula de cria zincada
Cage de élevage zingué

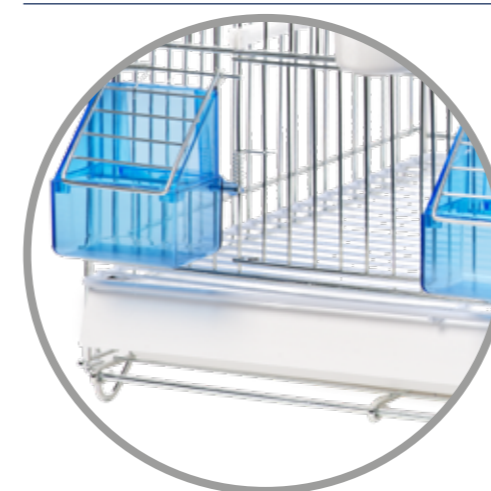

18 conf.
108 gabbie

cm 78 x 60 x 22h
22 kg



GABBIA COVA 58x30 CM LATERALI IN PLASTICA

Art. 326/B



cm. 58 x 30 x 39h
Gabbia cova plastificata
Plastified breeding cage
Jaula de cria plastificada
Cage de élevage plastifiée



Art. 326/Z



cm. 58 x 30 x 39h
Gabbia cova zincata
Breeding galvanized cage
Jaula de cria zincada
Cage de élevage zingué



18 conf.
108 gabbie

cm 78 x 60 x 22h
21 kg

Art. 326/SC



Gabbia cova
Breeding cage
Jaula de cria
Cage de élevage

SISTEMA CARTA
PAPER SYSTEM
SISTEMA PAPEL
SYSTEME PAPIER

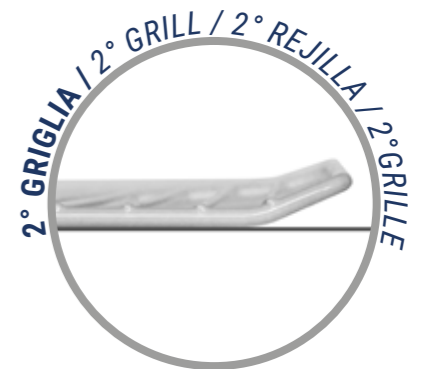
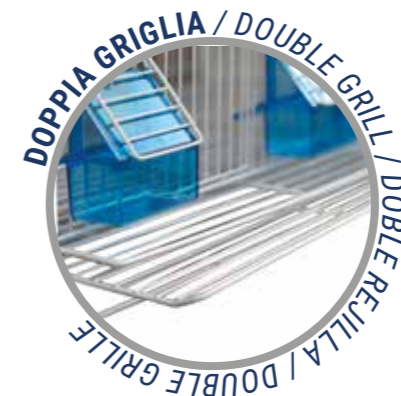

ACCESSORI COVA 58x30 CM

Art. 375



- cm. 58x37
Parete retro gabbia cova cm 58
Back wall for breeding cage cm 58
Pared trasera para jaula de cria cm 58
Mur d'arrière pour cage d'élevage cm 58



POSIZIONARE ALL'INTERNO GABBIA / TO PUT INSIDE THE CAGE



ACCESSORI COVA 58x30 CM

Art. 337



Sistema Voliera
Aviary System
Sistema voladora
Système Volière

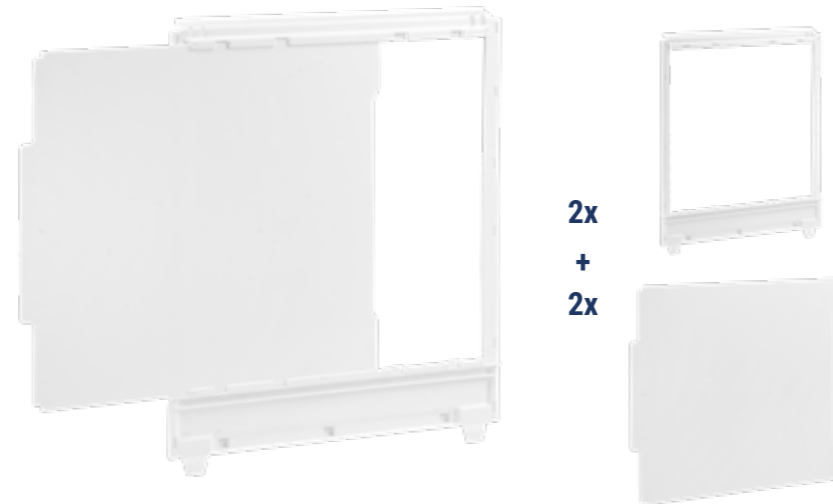

2x
+
2x

SISTEMA VOLIERA
AVIARY SYSTEM
SISTEMA AVIARIO
SYSTEME VOLIERE



Art. 356



Gancio per unione gabbie cm 58
Union hook for cage cm 58
Gancho de union jaula cm 58
Crochet pour union cage cm 58



Art. 334



Gancio ferma griglia
Grill's block
Bloc du grille
Bloque para rejilla



Art. 327



— cm. 31 x 39 x 2,5
Laterale in plastica per gabbia cova 58
Plastic side for breeding cage 58
Lateral en plastico para jaula de cria 58
Lateral en plastique pour cage d'élevage 58



Art. 328



— cm. 56,5 x 30 x 3
Cassetto per gabbia cova 58
Drawer for breeding cage 58
Bandeja jaula de cria 58
Tiroir pour cage d'élevage 58



ACCESSORI COVA 58x30 CM

Art. 331



Divisorio chiuso per gabbia cova 58
Closed dividing wall for breeding cage 58
Pared divisoria cerrada para jaula de cria 58
Cloison ferme pour cage d'élevage 58



Art. 330



— cm. 32 x 2 x 1
Guida per divisorio
Slide guide for dividing wall
Guia para pared divisoria
Guide pour cloison



Art. 332



Griglia per gabbia cova 58
Grill for breeding cage 58
Rejilla para jaula de cria 58
Grille pour cage d'élevage 58

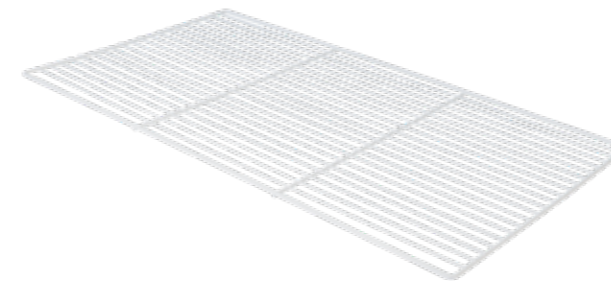

Art. 333



Griglia incurvata per gabbia cova 58
Curved grill for breeding cage 58
Rejilla incurvada para jaula de cria 58
Grille incurvée pour cage d'élevage 58

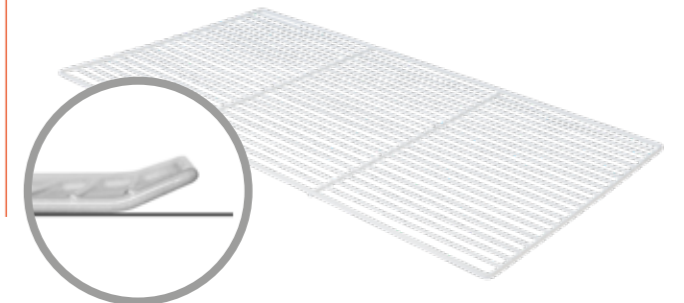

Art. 350



— cm. 31,6
Posatoio per gabbia da cova
Perch for breeding cage
Posadero para jaula de cria
Perche pour cage d'élevage

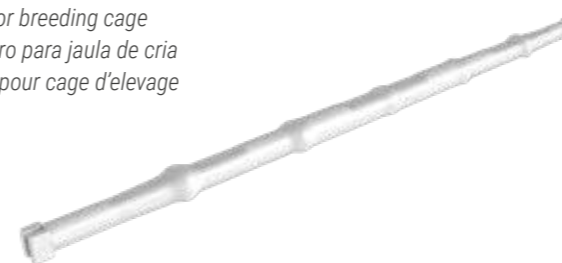

COMPATIBILE CON GABBIE COVA DA 55 CM E 58 CM
COMPATIBLE WITH BREEDING CAGES CM 55 AND CM 58
COMPATIBLE CON JAULA DE CRIA CM 55 Y CM 58
COMPATIBLE AVEC CAGES D'ELEVAGE 55 CM ET 58

Art. 424



cm 54 x 27,5
Carta bulinata per cova 58
Absorbent paper cage cm 58
Carta absorbente jaula cm 58
Papier absorbant cage cm 58



COMPATIBILE CON GABBIE 326 E 317
COMPATIBLE WITH CAGES 326 AND 317
COMPATIBLE CON JAULAS 326 Y 317
COMPATIBLE AVEC LES CAGES 326 AT 317



GABBIA COVA DA 60x40 CM FRONTALE PLASTIFICATO

Art.460



-cm 61 x 42 x 44h
Gabbia cova 60 Taormina
Breeding cage 60 Taormina
Jaula de cria 60 Taormina
Cage d'élevage 60 Taormina



RETRO IN PLASTICA
PLASTIC BACK WALL
PARED TRASERA EN PLASTICO
MUR D'ARRIER EN PLASTIQUE



22 conf.
44 gabbie



cm 79 x 47 x 22h
8,5 kg

GABBIA COVA DA 60x40 CM FRONTALE ZINCATO

Art. 462



-cm 61 x 42 x 44h
Gabbia cova 60 Porto Cervo
Breeding cage 60 Porto Cervo
Jaula de cria 60 Porto Cervo
Cage d'élevage 60 Porto Cervo



RETRO IN PLASTICA
PLASTIC BACK WALL
PARED TRASERA EN PLASTICO
MUR D'ARRIER EN PLASTIQUE



22 conf.
44 gabbie

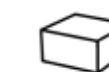

cm 79 x 47 x 22h
8,5 kg

Art. 461



cm 61 x 42 x 44h
Gabbia cova 60 Tropea
Breeding cage 60 Tropea
Jaula de cria 60 Tropea
Cage d'élevage 60 Tropea

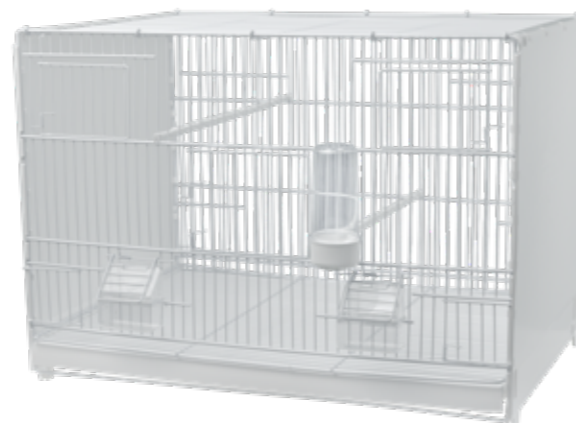

SALVA SPAZIO

1,5 CM



Art. 463



-cm 61 x 42 x 44h
Gabbia cova 60 Polignano
Breeding cage 60 Polignano
Jaula de cria 60 Polignano
Cage d'élevage 60 Polignano



RETRO IN RETE
GRILL BACK WALL
PARED TRASERA DE REJILLA
MUR D'ARRIER DE GRILLE



GABBIA COVA DA 90x40 CM FRONTALE PLASTIFICATO

Art. 420



cm 91,50 x 42 x 44,5h
Gabbia cova 90 Positano
Breeding cage 90 Positano
Jaula de cria 90 Positano
Cage d'élevage 90 Positano



RETRO IN PLASTICA
PLASTIC BACK WALL
PARED TRASERA EN PLASTICO
MUR D'ARRIER EN PLASTIQUE



28 conf.
56 gabbie

cm 94 x 48 x 16,5h
15 kg

Art. 421



cm 91,50 x 42 x 44,5h
Gabbia cova 90 Portofino
Breeding cage 90 Portofino
Jaula de cria 90 Portofino
Cage d'élevage 90 Portofino



SALVA SPAZIO



GABBIA COVA DA 120x40 CM FRONTALE PLASTIFICATO

Art. 400



cm 122 x 42 x 44,5h
Gabbia cova 120 Cortina
Breeding cage 120 Cortina
Jaula de cria 120 Cortina
Cage d'élevage 120 Cortina

RETRO IN PLASTICA
PLASTIC BACK WALL
PARED TRASERA EN PLASTICO
MUR D'ARRIER EN PLASTIQUE



22 conf.
44 gabbie

cm 79 x 47 x 22h
17 kg

Art. 401



cm 122 x 42 x 44,5h
Gabbia cova 120 Bormio
Breeding cage 120 Bormio
Jaula de cria 120 Bormio
Cage d'élevage 120 Bormio

RETRO IN RETE
GRILL BACK WALL
PARED TRASERA DE REJILLA
MUR D'ARRIER DE GRILLE



GABBIA COVA DA 120x40 CM FRONTALE ZINCATO

Art. 402



cm 122 x 42 x 44,5h
Gabbia cova 120 Sestriere
Breeding cage 120 Sestriere
Jaula de cria 120 Sestriere
Cage d'elevage 120 Sestriere



SALVA SPAZIO

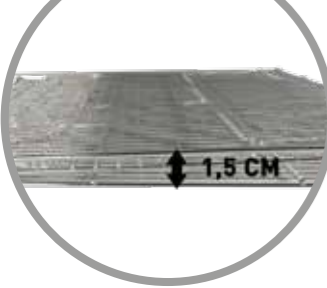

22 conf.
44 gabbie

cm 79 x 47 x 22h
17 kg

Art. 403



cm 122 x 42 x 44,5h
Gabbia cova 120 Livigno
Breeding cage 120 Livigno
Jaula de cria 120 Livigno
Cage d'elevage 120 Livigno



SALVA SPAZIO



ACCESSORI COVA 90 e 120 CM

Art. 396



cm 59,5 x 42 x 3,5h
Cassetto gabbia cova 120
Bottom breeding cage 120
Bandeja jaula de cria 120
Tiroir pour cage d'elevage 120



Art. 414



cm 44 x 42 x 4h
Cassetto gabbia cova 90
Drawer for breeding cage 90
Bandeja jaula de cria 90
Tiroir pour cage d'elevage 90



Art. 397



cm 42 x 44,5 x 1,5h
Laterale in plastica gabbia cova 90 e 120
Plastic side for breeding cage 90 and 120
Lateral de plastico jaula de cria 90 y 120
Lateral en plastique cage d'elevage 90 et 120



Art. 423



Griglia bianca per gabbia cova 90
White gril for breeding cage 90
Rejilla blanca para jaula de cria 90
Grille blanche pour cage elevage 90

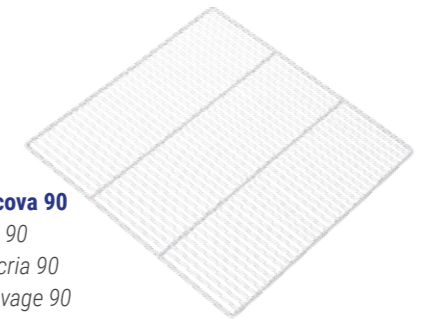

Art. 404



Griglia bianca per gabbia cova 120
White gril for breeding cage 120
Rejilla blanca para jaula de cria 120
Grille blanche pour cage elevage 120



Art. 405



Griglia zincata per gabbia cova 120
Metal gril for breeding cage 120
Rejilla zincada para jaula de cria 120
Grille zingue pour cage elevage 120

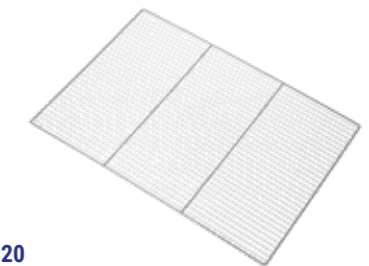

ACCESSORI COVA 90 e 120 CM

Art. 411



cm 41 x 34,5h
Divisorio in plastica per cova 90 e 120
Plastic divider breeding cage 90 and 120
Pared divisoria en plastico jaula 90 y 120
Cloison ferme pour cage d'elevage 90 et 120

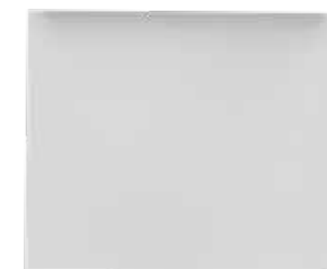

ACCESSORI COVA 90 e 120 CM

Art. 413

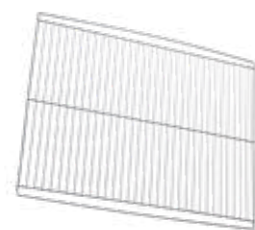

cm 41 x 34,5h
Divisorio in ferro per cova 90 e 120
 Iron dividing wall for cage 90 and 120
 Pared divisoria en hierro para jaula 90 y 120
 Cloison en fer pour cage 90 et 120

Art. 442

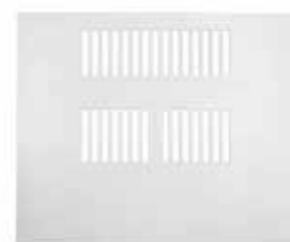

cm 41 x 34,5h
Divisorio in plastica grigliato
 Plastic grill divider
 Rejilla divisoria en plastico
 Grille diviseur en plastique



Art. 407



cm 43
Posatoio con perno per gabbia 90/120
 Perch with pin for cage 90/120
 Posadero con punta para jaula 90/120
 Perche avec pointe pour cage 90/120



PER GABBIE CODICE 401/403
 FOR CAGES 401/403
 PARA JAULA 401/403
 POUR CAGES 401/403

Art. 416



cm 44 x 42
Parete retro per gabbia 90
 Back wall for breeding cage 90
 Pared trasera para jaula de cria 90
 Mur d'arriere pour cage d'elevage 90

Art. 408



cm 43
Posatoio per gabbia 90/120
 Perch for cage 90/120
 Posadero para jaula 90/120
 Perche pour cage 90/120



PER GABBIE CODICE 400/402/420/421
 FOR CAGES 400/402/420/421
 PARA JAULA 400/402/420/421
 POUR CAGES 400/402/420/421

Art. 399



cm 60 x 41,5
Parete retro per gabbia 120
 Back wall for breeding cage 120
 Pared trasera para jaula de cria 120
 Mur d'arriere pour cage d'elevage 120

Art. 409



Maniglia universale
 Universal handle
 Manilla universal
 Poignee universelle

Art. 410



Porta mangiatoia interno
 Internal feeder holder
 Porta comedero interno
 Porte mangeoire interieur

Art. 417

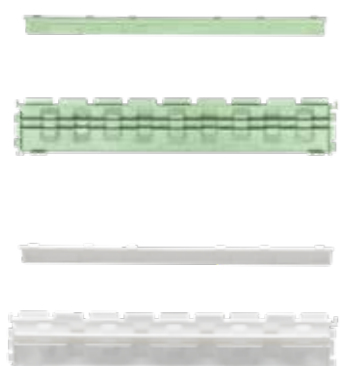

Kit guide per cova 90
 Guides for cage 90
 Guida para jaula 90
 Guide pour cage 90

Art. 398

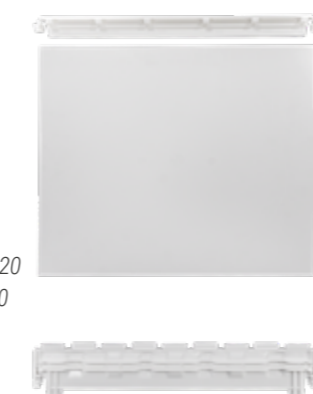

Kit voliera gabbia cova 90 e 120
 Aviary kit breeding cage 90/120
 Sistema voladora para jaula de cira 90/120
 System voliere pour cage elevage 90/120



Art. 425



cm 57 x 38
Carta bulinata per cova 120
 Absorbent paper cage cm 120
 Carta absorbente jaula cm 120
 Papier absorbant cage cm120

COMPATIBILE CON GABBIE 400/401/402/403
 COMPATIBLE WITH CAGES CODE 400/401/402/403
 COMPATIBLE CON JAULAS 400/401/402/403
 COMPATIBLE AVEC LES CAGES 400/401/402/403

Art. 426



cm 41 x 38
Carta bulinata per cova 90
 Absorbent paper cage cm 90
 Carta absorbente jaula cm 90
 Papier absorbant cage cm 90

COMPATIBILE CON GABBIE 420/421
 COMPATIBLE WITH CAGES CODE 420/421
 COMPATIBLE CON JAULAS 420/421
 COMPATIBLE AVEC LES CAGES 420/421

CARRELLI PER GABBIE 60 - 90 - 120 CM

Art. 455



Carrello 60 per gabbie cova
 Trolley 60 for breeding cages
 Carro 60 para jaulas de cria
 Chariot 60 pour cages d'élevage



Art. 429



cm 92 x 44 x 36h
Carrello 90 per gabbie cova
 Trolley 90 for breeding cages
 Carro 90 para jaulas de cria
 Chariot 90 pour cages d'élevage



Art. 418



cm 122,50 x 44 x 36h
Carrello 120 per gabbie cova
 Trolley 120 for breeding cages
 Carro 120 para jaulas de cria
 Chariot 120 pour cages d'élevage



Art. 419



cm 182,5 x 44 x 36h
Carrello 180 per gabbie cova
 Trolley 180 for breeding cages
 Carro 180 para jaulas de cria
 Chariot 180 pour cages d'élevage

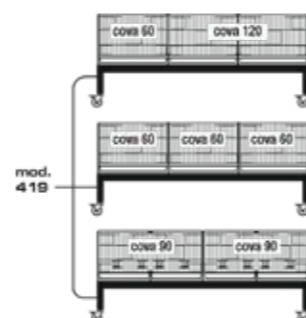

STRUTTURE GABBIE COVA DA 58 CM
 STRUCTURE FOR BREEDING CAGES CM 58
 ESTRUCTURAS PARA JAULAS DE CRIA CM 58
 STRUCTURE POUR CAGES D'ELEVAGE CM 58

SISTEMA CARTA
 PAPER SYSTEM - SISTEMA PAPEL - SYSTEME PAPIER
FISSAGGIO A MURO
 WALL FASTENING - SE FIJA A LA PARED - FIXATION A MUR

Art. 340



Struttura per sistema carta 2 x 4
 Structure for paper system 2 x 4
 Estructura para sistema papel 2 x 4
 Structure pour système papier 2 x 4

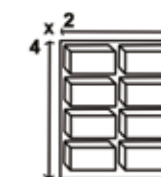

cm. 135 x 41 x 199h



Art. 341



Struttura per sistema carta 4 x 4
 Structure for paper system 4 x 4
 Estructura para sistema papel 4 x 4
 Structure pour système papier 4 x 4

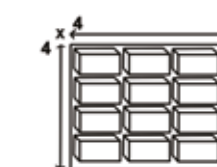

cm. 255 x 41 x 199h

SISTEMA CON CASSETTO
 DRAWER'S SYSTEM - SISTEMA CON BANDEJA - SYSTEM AVEC TIROIR
FISSAGGIO A MURO
 WALL FASTENING - SE FIJA A LA PARED - FIXATION A MUR

Art. 342



Strutt. per sistema cassetto 2 x 4
 Struct. for drawer's system 2 x 4
 Estructura para sistema bandeja 2 x 4
 Structure pour système avec tiroir 2 x 4



cm. 120 x 41 x 199h



Art. 343



Strutt. per sistema cassetto 4 x 4
 Struct. for drawer's system 4 x 4
 Estructura para sistema bandeja 4 x 4
 Structure pour système avec tiroir 4 x 4



cm. 240 x 41 x 199h

STRUTTURA FRONTE E RETRO
 BACK AND FRONT SIDE STRUCTURE
 ESTRUCTURA TRASERA Y DELANTERA
 STRUCTURE AVANT ET ARRIÈRE

SISTEMA CARTA
 PAPER SYSTEM - SISTEMA PAPEL - SYSTEME PAPIER

Art. 345



Struttura doppia per sistema carta 2 x 4
 Double structure for paper system 2 x 4
 Estructura doble para sistema papel 2 x 4
 Structure double pour système papier 2 x 4



cm. 135 x 80 x 205h

Art. 346



Struttura doppia per sistema carta 4 x 4
 Double structure for paper system 4 x 4
 Estructura doble para sistema papel 4 x 4
 Structure double pour système papier 4 x 4



GABBIE NON INCLUDE
 CAGES NOT INCLUDED

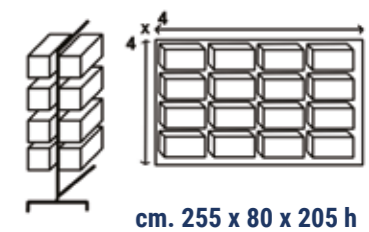

cm. 255 x 80 x 205 h

SISTEMA CON CASSETTO
DRAWER'S SYSTEM - SISTEMA CON BANDEJA - SYSTEM AVEC TIROIR

Art. 347



Struttura doppia per sistema cassetto 2 x 4
Double structure for drawer's system 2 x 4
Estructura doble para sistema bandeja 2 x 4
Structure double pour système avec tiroir 2 x 4

16 GABBIE



cm. 120 x 80 x 205h

Art. 348



Struttura doppia per sistema cassetto 4 x 4
Double structure for drawer's system 4 x 4
Estructura doble para sistema bandeja 4 x 4
Structure pour système avec tiroir 4 x 4

32 GABBIE



cm. 240 x 80 x 205h

Art. 349



- Ø 12 x 33 cm
Rotolo di carta
Paper roll
Rollo de papel
Rouleau de papier



Art. 344



Ruote per struttura singola art. 340-342
Wheels for single structure art. 340-342
Ruedas estructura individual art. 340-342
Roues pour structure individuel art. 340-342

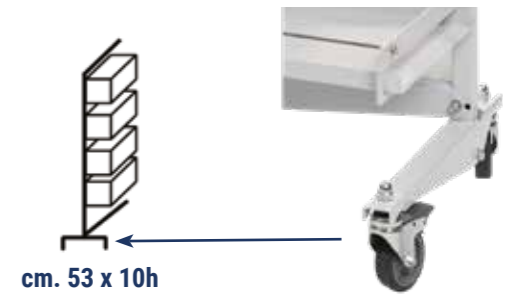

Art. 439



cm 119 X 33 X 36h
Carrello 120 per gabbie cova cm 58
Trolley 120 for breeding cages cm 58
Carro 120 para jaulas de cria cm 58
Chariot 120 pour cages d'eleavage cm 58



COMPATIBILE CON GABBIE 326
COMPATIBLE ONLY WITH CAGE 326

Art. 454



cm
Carrello 58 per gabbia cova
Trolley 58 for breeding cage
Carro 58 para jaulas de cria
Chariot 58 pour cages d'eleavage



GABBIE DA ESPOSIZIONE
EXPOSITION CAGES - JAULAS EXPOSICION - CAGE EXPOSITION

IDEALE PER LA PREPARAZIONE
PERFECT FOR PREPARATION - PERFECTO PARA LA PREPARACION - PARFAIT POUR LA PREPARATION

IDEALE PER LE MOSTRE
PERFECT FOR SHOWS - PERFECTO PARA MUESTRAS - PARFAIT POUR MONTRE

Art. 315/FB1



cm. 36 x 17 x 30h
Gabbia espos. 1 porta frontale bianco
Exposition cage 1 door white frontal
Jaula exposicion 1 puerta y frontal blanco
Cage exposition 1 porte frontal blanc



Art. 315/FN1



cm. 36 x 17 x 30h
Gabbia espos. 1 porta frontale nero
Exposition cage 1 door black frontal
Jaula exposicion 1 puerta y frontal negro
Cage exposition 1 porte frontal noir



Art. 315/SP



cm. 36 x 17 x 30h
Gabbia espos. con foro laterale
Exposition cage with lateral hole
Jaula exposicion con agujero lateral
Cage exposition avec trou lateral



SPECIALE CON FORO LATERALE

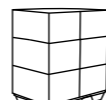

cm. 58 x 39 x 39h 160 pcs

Art. 315/FN3V



cm. 36 x 17 x 30h
Gabbia espos. verde 3 porte front. nero
Green exposition cage 3 door black frontal
Jaula exposicion verde 3 puertas y frontal negro
Cage exposition vert 3 portes frontal noir



Art. 315/FB3



cm. 36 x 17 x 30h
Gabbia espos. 3 porte frontale bianco
Exposition cage 3 doors white frontal
Jaula exposicion 3 puertas y frontal blanco
Cage exposition 3 portes frontal blanc



Art. 315/FB3A



cm. 36 x 17 x 30h
Gabbia espos. 3 porte frontale bianco
Exposition cage 3 doors white frontal
Jaula exposicion 3 puertas y frontal blanco
Cage exposition 3 portes frontal blanc



MANGIATOIE IN POSIZIONE PIÙ ALTA



cm. 58 x 39 x 39h 160 pcs

Art. 315/FN3



cm. 36 x 17 x 30h
Gabbia espos. 3 porte frontale nero
 Exposition cage 3 doors black frontal
 Jaula exposicion 3 puertas y frontal negro
 Cage exposition 3 portes frontal noir

Art. 315/FZ3



cm. 36 x 17 x 30h
Gabbia espos. 3 porte e frontale zincato
 Exposition cage 3 doors galvanized frontal
 Jaula exposicion 3 puertas y frontal zincado
 Cage exposition 3 portes frontal zingue

Art. 315/SC



cm. 36 x 17 x 30h
Gabbia espos. 3 porte sistema carta
 Exposition cage 3 doors paper system
 Jaula exposicion 3 puertas sistema papel
 Cage exposition 3 portes système papier

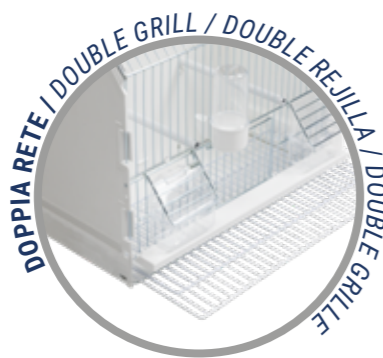

SISTEMA CARTA
 PAPER SYSTEM - SISTEMA PAPEL -
 SYSTEME PAPIER



cm. 58 x 39 x 39h

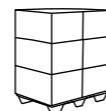

160 pcs

Art. 315/C

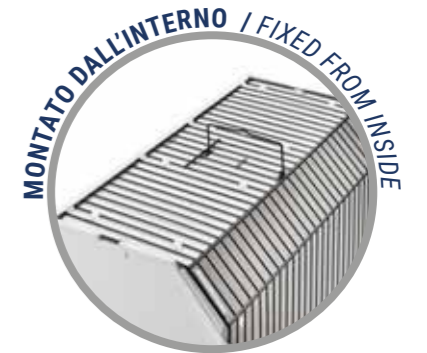

Coperchio per gabbia esposizione art. 315
 Cover for exposition cage art. 315
 Tapa para jaula de exposicion art. 315
 Couvercle pour cage d'exposition art. 315

Art. 315/F



Cassetto per gabbia esposizione art. 315
 Drawer for exposition cage art. 315
 Bandeja para jaula de exposicion art. 315
 Tirorir pour cage d'exposition art. 315

Art. 315/T



IDEALE PER TRASFORMARE LA GABBIA IN SISTEMA CARTA
 IDEAL TO TRASFORM THE CAGE IN PAPER SYSTEM
 IDEAL PARA TRANSFORMAR LA JAULA EN SISTEMA PAPEL
 IDÉAL POUR TRANSFORMER LA CAGE EN SYSTÈME DE PAPIER

Telaio per gabbia esposizione art. 315
 Frame for exposition cage art. 315
 Telar para jaula de exposicion art. 315
 Cadre pour cage d'exposition art. 315

Art. 315/G

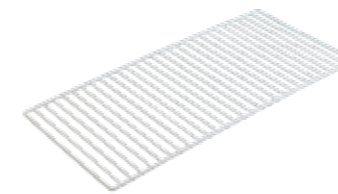

Griglia per gabbia esposizione art. 315
 Grill for exposition cage art. 315
 Rejilla para jaula de exposicion art. 315
 Grille pour cage d'exposition art. 315

Art. 315/B



Bandina per gabbia art. 315
 Drawer's cover for cage art.315
 Frontal para bandeja jaula art. 315
 Couvercle du tiroir cage art. 315



STRUTTURE PER GABBIE DA ESPOSIZIONE

STRUCTURE FOR EXPOSITION CAGES - ESTRUCTURAS PARA JAULAS DE EXPOSICION - STRUCTURE POUR CAGE D'EXPOSITION

SISTEMA CARTA

PAPER SYSTEM - SISTEMA PAPEL - SYSTEME PAPIER

Art. 351



Struttura per sistema carta 4 x 5

Structure for paper system 4 x 5
Estructura para sistema papel 4 x 5
Structure pour système papier 4 x 5



RETRO STRUTTURA

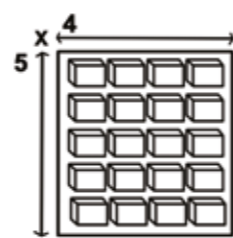

cm. 160 x 22 x 198h



Art. 354



- Ø 10 x 18 cm
Rotolo di carta
Paper roll
Rollo de papel
Rouleau de papier



SISTEMA CON PADELLA

DRAWER'S SYSTEM - SISTEMA CON BANDEJA - SYSTEM AVEC TIROIR

Art. 352



Struttura per sistema cassetto 4 x 5

Structure for drawer's system 4 x 5
Estructura para sistema bandeja 4 x 5
Structure pour système avec tiroir 4 x 5

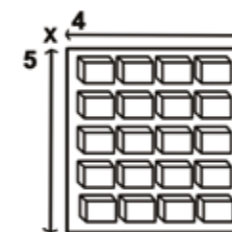

cm. 150 x 22 x 198h



RETRO STRUTTURA



GANCI PER APPENDERE LE GABBIE

Art. 353



Ruote per struttura singola
Wheels for single structure
Ruedas para estructura individual
Roues pour structure individuel

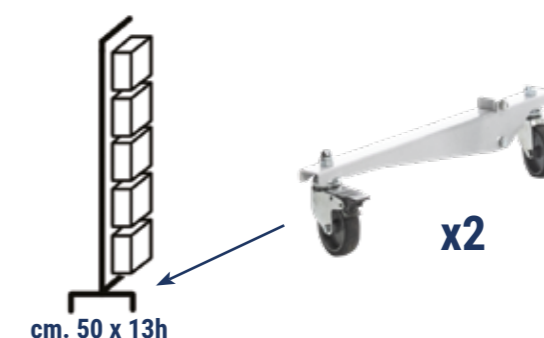

cm. 50 x 13h

x2



Art. 443

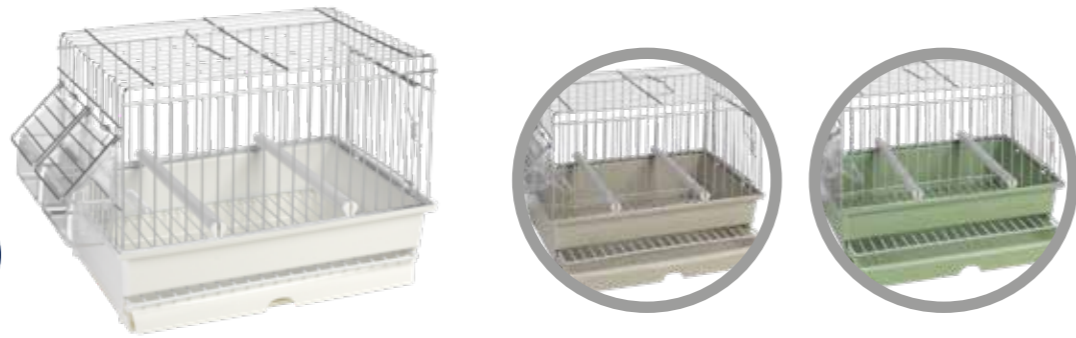

— cm. 27,5 x 17 x 20h
Gabbia trasportino Brooklyn
 Transport cage Brooklyn
 Jaula transportín Brooklyn
 Cage de transport Brooklyn

Art. 445



— cm. 27,5 x 17 x 35,5h
Gabbia New York
 Cage New York
 Jaula New York
 Cage York

Art. 444



— cm. 27,5 x 17 x 27h
Gabbia trasportino Manhattan
 Transport cage Manhattan
 Jaula transportín Manhattan
 Cage de transport Manhattan

Art. 446

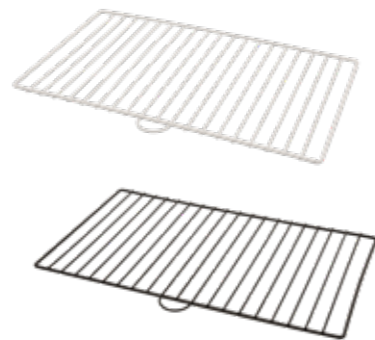

— **Griglia per gabbia 443 - 444 - 445**
 Grill for cages 443 - 444 - 445
 Rejilla para jaulas 443 - 444 - 445
 Grille pour cages 443 - 444 - 445

Art.383



— cm. 22,2 x 14,5 x 2h
Griglia per gabbie 20/21/288
 Grill for cages 20/21/288
 Rejilla para jaulas 20/21/288
 Gril pour cages 20/21/288

Art. 055



— cm. 24 x 16 x 19h
Gabbia per imbecco
 Cage for manual feeding
 Jaula para empapuzar
 Cage pour alimentation

Art. 020



— cm. 24 x 16 x 20h
Gabbia Cantori
 Songbird cage
 Jaula canto
 Cage pour oiseaux de chant

Art. 377



— cm. 24,5 x 17 x 18,5h
Gabbia Cantori per esposizione
 Songbird cage for exhibition
 Jaula canto para exposiciones
 Cage oiseaux de chant pour exposition

Art. 428



— cm 48 x 22 x 43h
Valigia 8 posti verde
 Case with 8 places green
 Maleta con 8 lugares verde
 Valise avec 8 lieux vert

PRIMA DELLE MOSTRE
 BEFORE EXHIBITION - ANTES DE LAS EXPOSICIONES - AVANT L'ESPOSITION

DURANTE LE MOSTRE
 DURING EXHIBITION - DURANTE LAS EXPOSICIONES - PENDANT L'ESPOSITION

PERFETTO PER IL TRASPORTO
 SUITABLE FOR TRANSPORT - PERFECTA PARA EL TRANSPORTE - PARFAIT POUR LE TRANSPORT

COPERTA PER QUESTO PRODOTTO DISPONIBILE A PAGINA 16

Art. 061



— cm. 28 x 20 x 7h
Fondo bengalino
 Bengalino bottom
 Fondo jaula bengalino
 Fond Bengalino



Art. 062



— cm. 31 x 20 x 9h
Fondo jolly
 Jolly bottom
 Fondo jaula jolly
 Fond jolly



Art. 075



— cm. 44 x 27 x 8h
Fondo gabbia cova
 Brooding cage bottom
 Fondo jaula cria
 Fond pour cage de couvée



Art. 079



— cm. 38 x 24 x 10,5h
Fondo lusso
 Lusso bottom
 Fondo jaula lujo
 Fond luxe



Art. 095



— cm. 58 x 32 x 9h
Fondo gabbia cova
 Brooding cage bottom
 Fondo jaula cria
 Fond pour cage de couvée



Art. 114



— cm. 67,7 x 35,2 x 12,5h
Fondo cova
 Brooding cage bottom
 Fondo jaula de cria
 Fond pour cage de couvée

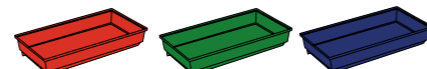

Art. 042



— cm. 3,5 x 1,5
Gancio per fondo gabbia
 Hook for cage bottom
 Gancho para fondo de jaula
 Crochet pour fond de cage

Art. 077



— cm. 5 x 1,5
Gancio fermafondo lungo
 Long hook for cage bottom
 Gancho largo para fondo jaula
 Crochet pour fond de cage

Art. 088



— cm. 6 x 7
Portina p/g fili verticali
 Door for cage with vertical wires
 Puerta para jaula hierro vertical
 Porte pour grille avec vertical fils

Art. 089



— cm. 6 x 7
Portina p/g fili orizzontali
 Cage door with horizontal wires
 Puerta para jaula hierro horizontal
 Porte pour grille avec horizontal fils

Art. 388



cm 7,5 x 6,5h
Portina in ferro con molla
 Iron door with spring
 Porta en hierro con molla
 Porte en fer avec ressort

COMPATIBILE CON GABBIE 315
 COMPATIBLE WITH CAGES CODE 315
 COMPATIBLE CON JAULAS 315
 COMPATIBLE AVEC LES CAGES 315

Art. 135



— cm. 9 x 10
Altalena
 Swing
 Columpio altalena
 Balançoire

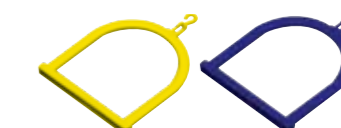

Art. 050/E



Terminale esterno per posatoio
External perch ends
Terminal externo para posador
Embout extérieur pour perchoir



Ø10 Ø12

Art. 050/I



Terminale per paletto
Perch ends
Terminal para posador
Embout perchoir



Ø10 Ø12

Art. 355



– cm. 11x7,5x32h
Posatoio Sunset
Sunset Perch
Percha Sunset
Perchoir Sunset



Art. 085



– cm. 5
Posatoio plastica
Plastic perch
Posador plastico
Perche plastique



Art. 272



– cm. 16,5
Posatoio plastica
Plastic perch
Posador plastico
Perche plastique



Art. 113



1 mt.
Paletti trafilati
Drawn perch
Percha trefilada
Perchoir trefilé



Ø 22 / Ø 18 / Ø 12 / Ø 10

Art. 081



– cm. 18
Posatoio
Perch
Posador
Perche

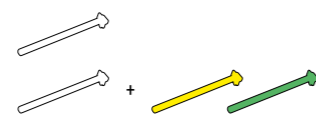

Art. 124

Spazzolino d.16
Brush d.16
Cepillo d.16
Brosse d. 16



Art. 124/A

Spazzolino d.50
Brush d.50
Cepillo d.50
Brosse d. 50



Art. 124/B

Spazzolino d. 40
Brush d. 40
Cepillo d. 40
Brosse d. 40



Art. 124/C

Spazzolino d. 75
Brush d. 75
Cepillo d. 75
Brosse d. 75



Art. 080



– cm. 22
Posatoio
Perch
Posador
Perche

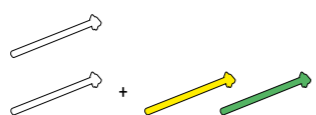



Mangiatoie

*Feeders
Comederos
Mangeoires*

96

Uccelli Selvatici

WILD BIRDS / AVES SILVESTRES
/OISEAUX DE LA NATURE

Art. 148



Kg.1 - lt. 1

Comber mangiatoia abbeveratoio

Comber feeder/water dispenser

Comber comedero/bebedero

Comber mangeoire/abreuvoir



Art. 450



– ø 15 x 27 h

Mangiatoia per semi Kiku

Kiku seeds feeders

Comedero Kiku para semilla

Mangeoire Kiku pour graines



IDEALE ANCHE PER VOLIERE!

PERFECT FOR AVIARY
PERFECTO PARA VOLADORAS
IDÉAL POUR VOLIERE

Art. 149



Kg.1 - lt. 1

Comber mangiatoia/beverino da esterno

External Comber feeder/water dispenser

Comber comedero/bebedero para externo

Comber mangeoire/abreuvoir extérieur



Art. 451



– ø 15 x 27 h

Mangiatoia per palle di grasso Ume

Ume fat balls feeder

Comedero Ume para bolas de grasa

Mangeoire Ume pour boules de graisse





Maisonette 98

*Maisonette
Mansion
Cage pour rongeurs*

Sifoni 100

*Siphons
Bebederos
Abreuvoir pour rongeurs*

Accessori 101

*Accessories
Accesorios
Accessoires*

Tartarughiere 102

*Turtles tanks
Tortugueras
Cage pour tortues*

Roditori e Tartarughe

RODENTS & TURTLES / ROEDORES & TORTUGAS
/ RONGEURS & TORTUES

Art. 280



— cm. 44 x 34 x 20h

Maisonette Candy

Candy hamster cage
Jaula para hamster Candy
Cage Hamster Candy



Art. 370



— cm. 52x38x24h

Maisonette Cleo

Cleo hamster cage
Jaula para hamster cleo
Cage pour hamster Cleo



Art. 174



— cm. 50 x 38 x 25h

Maisonette Baby

Hamster cage Baby
Jaula para hamster Baby
Cage Hamster Baby



Art. 150



— cm. 60 x 40 x 30h

Maisonette

Hamster cage
Jaula hamster
Cage rongeurs



Art. 151



— cm. 60 x 40 x 30h

Maisonette lusso

Luxury hamster cage
Jaula lujo para hamster
Cage hamster luxe



Art. 153



— cm. 60 x 40 x 30h

Maisonette lusso vuota

Empty luxury cage
Jaula lujo vacia
Cage vide de luxe



Art. 126



— cm 15,5 x 11 x 13h

Casetta per criceto

Hamster house
Caseta hamster
Maison hamster



Art. 102

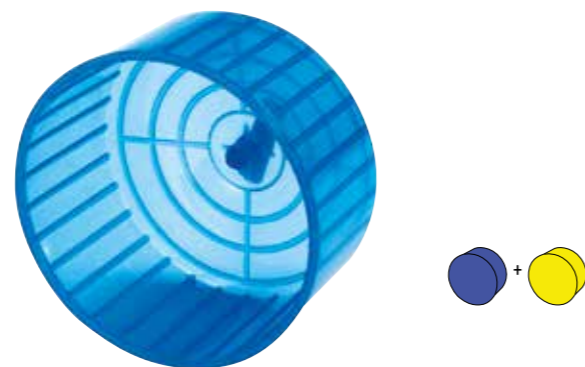

ø 14 x 9h
Ruota per criceto chiusa
Closed hamster wheel
Rueda para hamster cerrada
Roue pour hamster fermé

Art. 166



ø 32 mm
Anello con ventosa
Ring with suction cap
Anillo con ventosa
Anneau avec ventouse

Art. 167



ø 50 mm
Anello doppio con ventosa
Double ring with suction cap.
Anillo doble con ventosa
Anneau avec double ventouse

Art. 086



cc. 90
Sifone criceto
Hamster siphon
Bebedero hamster
Abreuvoir Hamster

Art. 389



cc. 70
Sifone roditori Ghiotto
Ghiotto rodents siphon
Bebedero roedor Ghiotto
Abreuvoir rongeurs Ghiotto

Art. 044



— cm. 7 x 4 x 3h
Mangiatoia criceto
Hamster feeder
Comedero hamster
Mangeoire hamster

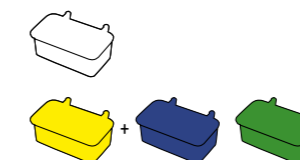

Art. 144



ø 7 x 3,5h
Mangiatoia criceto rotonda con base
Hamster feeder with base
Comedero hamster redondo con base
Mangeoire pour hamster avec base

Art. 390



cc. 90
Sifone roditori Bijou
Bijou rodents siphon
Bebedero roedor Bijou
Abreuvoir rongeurs Bijou

Art. 391



cc. 200
Sifone Jingle
Jingle siphon
Bebedero Jingle
Abreuvoir Jingle

Art. 165



— cm. 25 x 9 x 16h
Portafieno
Hay holder
Porta heno
Porteur de foin

Art. 300



Confezione di fibra di cotone per Roditori
Rodent cotton fibre's packaging
Confeccion de fibra de coton para roedores
Paquet de fibres de coton pour rongeurs

Art. 392



cc. 200
Sifone Elliot c/ventose
Elliot siphon w/suction caps
Bebedero Elliot c/ventosa
Abreuvoir Elliot a/ventouse

Art. 393



cc. 400
Sifone roditori Elvis
Elvis rodents siphon
Bebedero roedor Elvis
Abreuvoir rongeurs Elvis

Art. 154



Trappola per topi
Mouse trap
Trampa para ratones
Souricière

Art. 163



— cm. 31,5 x 22 x 7h
Tartarughiera Oasi
Oasis turtle tank
Tortuguera Oasis
Bacs á tortues Oasi



Art. 198



— cm. 40 x 27 x 9,5h
Tartarughiera Oasi Maxi
Oasis Maxi turtle tank
Tortuguera Oasis Maxi
Bacs á tortues Oasi Maxi



Art. 183



— cm. 43 x 32 x 9,5h
Tartarughiera Maxi
Maxi turtle tank
Tortuguera Maxi
Bacs á tortues Maxi



Art. 164



ø 24,5 x 6,5h
Tartarughiera Laguna
Laguna turtle tank
Tortuguera Laguna
Bacs á tortues Laguna



Art. 312



— cm 44 x 34 x 12h
Tartarughiera Ischia
Ischia Turtletank
Tortuguera Ischia
Bacs á tortues Ischia



Art. 281



— cm. 44 x 34 x 20h
Tartarughiera Daffy
Daffy turtle tank
Tortuguera Daffy
Bacs á tortues Daffy



Art. 371



— cm. 52x38x24h
Tartarughiera Toby
Turtle tank Toby
Tortuguera Toby
Bacs á tortues Toby



Art. 372



— cm. 52x38x24h
Tartarughiera Sammy
Turtle tank Sammy
Tortuguera Sammy
Bacs á tortues Sammy



Art. 175



8 033844 762027



— cm. 50 x 38 x 25h

Tartarughiera Baby

Small turtle tank

Tortuguera Baby

Bacs á tortues Baby



Art. 152



8 033844 761716



— cm. 60 x 40 x 30h

Tartarughiera

Turtle tank

Tortuguera

Bacs á tortues

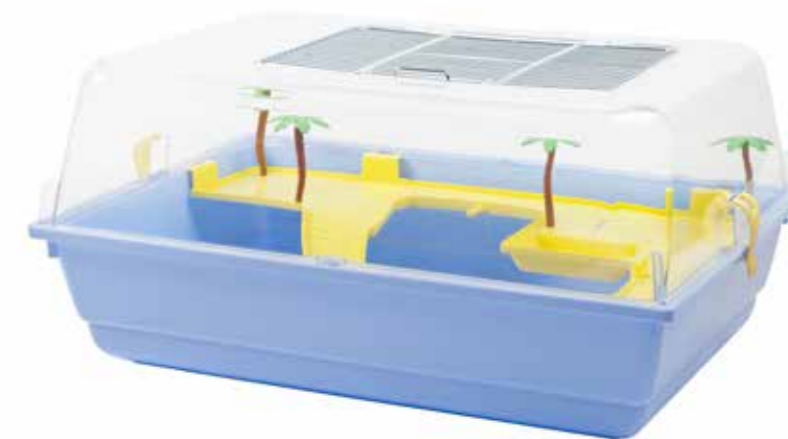

Art. 176



8 033844 762034



— cm. 50 x 38 x 25h

Tartarughiera Elba

Elba turtle tank

Tortuguera Elba

Bacs á tortues Elba



Art. 123



8 033844 761402



— cm. 7 x 3

Gancio fermafondo universale

Universal bottom hook

Gancho universal para fondo

Universel crochet





Trasportini 105

Transport
Transportin
Cage de transport

Lettiere 109

Litters
Lettieras
Litières

Ciotole 110

Bowls
Comederos
Bols



Canini e Gatti

DOGS & CATS / PERROS & GATOS / CHIENS & CHATS

Art. 286



— **cm. 49 x 33 x 31h**
Trasportino Calipso
 Calipso transporter
 Transportino Calipso
 Cage de transport Calipso



Art. 283



— **cm. 44 x 34 x 12h**
Toilette Felix con cornice
 Complete Felix toilet
 Bano Felix con cornisa
 Toilette Felix avec cadre



Art. 138



— **cm. 49 x 38 x 14,5h**
Toilette Silvestro completa
 Complete Silvestro toilet
 Toilet Silvestro completa
 Toilette Silvestro avec cadre



Art. 189



— **cm. 43 x 26 x 37h**
Trasportino Penelope
 Penelope transporter
 Transportino Penelope
 Cage de transport Penelope



Art. 156



— **cm. 9 x 25 x 3,5h**
Paletta igienica gatto
 Waste shovel
 Paleta higienica
 Palette hygienique pour chat



Art. 143



— **cm. 16 x 40**
Ricambi sac. Snoopy 24 pz.
 Snoopy refill bags 24 pz.
 Recambio bolsa recogedor higienico Snoopy
 Pieces de Rechange pour Snoopy



Art. 357



Ciotola Minou
Bowl Minou
Comedero gato Minou
Bol Minou

Lt. 0,2



Art. 162/18



Ciotola
Bowl
Comedero
Bol

Lt. 1,5



Art. 358



Ciotola Bizet
Bowl Bizet
Comedero gato Bizet
Bol Bizet

Lt. 0,3



Art. 162/20



Ciotola
Bowl
Comedero
Bol

Lt. 1,2



Art. 359



Ciotola Matisse
Bowl Matisse
Comedero gato Matisse
Bol Matisse

Lt. 0,5



Art. 162/T



Ciotola tripla
Triple bowl
Comedero triple
Triple Bol



Art. 162/14



Ciotola per Cocker
Cocker Bowl
Comedero para Cocker
Bol pour Cocker

Lt. 0,85



Art. 360



Ciotola doppia Romeo
Double Bowl Romeo
Comedero doble Romeo
Double Bol Romeo

Lt. 0,3 x 2



Art. 162/24



Ciotola
Bowl
Comedero
Bol

Lt. 3,5



Art. 162/26



Ciotola
Bowl
Comedero
Bol

Lt. 6



CODICE	DESCRIZIONE	PAG
001/A	Scheda a 4 cove	57
003	Mangiatoia ganci plastica	42
005	Mangiatoia colombi griglia plastica	44
006	Mangiatoia colombi griglia ferro	44
007	Molletta gancio	46
008	Nido piccolo	50
009	Nido grande	50
010	Uova piccole	59
010/C	Uova piccole colorate	59
011	Uova grandi	59
012	Mangiatoia att. dir. piccola	35
013	Mangiatoia att. dir. grande	35
015	Mangiatoia pappagallo c/ferri	41
017	Mangiatoia Napoli	32
018	Beverino corto	26
018/F	Beverino corto fumè	26
020	Gabbia cantori da preparazione	87
022	Mangiatoia piccola c/ ferri	40
022/G	Mangiatoia piccola c/ ferri con griglia	40
024	Mangiatoia esterna	33
025/G	Mangiatoia universale con griglia	43
026	Portanido in ferro Ø 10	51
028	Mangiatoia mezzaluna	34
033	Portaseppia g/plastica	46
034	Sifone Firenze	26
035	Mangiatoia mezzaluna ganci	34
036	Laterale in plastica per gabbia cova 55	60
037/A	Bandina frontale gabbia cova 55	60
038	Sifone lungo	26
039	Nido interno	50
041	Portasali	45
042	Gancio per fondo gabbia	87
043	Mangiatoia rett. media c/alette	41
044	Mangiatoia criceto	101
045	Mangiatoia piccola rett. c/ferri	40
046	Vaschetta bagno interna	47
049	Bagno Reggio	47
050/I	Terminale per paletto	90
050/E	Terminale esterno per posatoio	90
051	Mangiatoia Reggio	43
052	Mangiatoia Reggio c/ferri	43
053	Mangiatoia Parma	40
054	Mangiatoia Parma c/ ferri	40
055	Gabbia per imbecco	86
056	Nido esterno ferro/pl.	50
057	Portamedicinali	46
058	Sifone per polli	32

CODICE	DESCRIZIONE	PAG
059	Nido esterno lusso	50
059/V	Nido esterno lusso	50
060/A	Sifone Lucca con anello	27
061	Fondo bengalino	88
062	Fondo jolly	88
064	Fondo gabbia cova 55	60
065	Sifone mang. pappagalli	31
066	Sifone Napoli	31
068	Sifone Reggio	27
069	Portauovo	46
070	Portabiscotto	46
071	Mangiatoia girasole	45
072	Mangiatoia ovale	45
073	Mangiatoia girasole c/base	45
074	Bagno esterno lux	47
075	Fondo gabbia cova	87
077	Gancio fermafondo lungo	87
078	Pinza Reggio	59
079	Fondo lusso	87
080	Posatoio	90
081	Posatoio	90
082	Portaseppia	46
083	Nido perla	54
084	Nido diamante	54
085	Posatoio plastica	90
086	Sifone criceto	100
087	Sifone banana	27
088	Portina p/g fili verticali	89
089	Portina p/g fili orizzontali	89
094	Portapastoncino lusso	45
094/A	Portapastoncino lusso alto	45
095	Fondo gabbia cova	87
097	Raccoglitore universale	56
097/P	Raccoglitore universale pieno	56
098	Mangiatoia per voliera bianca	44
099	Mangiatoia per voliera trasparente	44
100	Mangiatoia per voliera trasparente c/ferri	43
101	Mangiatoia per voliera bianca c/f	43
102	Ruota per criceto chiusa	100
103	Mangiatoia Spagna 2000	33
105	Mangiatoia Italia 2000	33
113	Paletti trafilati	113
114	Fondo cova	87
115	Mangiatoia economy Ø 24	39
115/A	Mangiatoia economy Ø 28	39
116	Mangiatoia economy Ø 24	39
116/A	Mangiatoia economy Ø 28	39

CODICE	DESCRIZIONE	PAG
117	Mangiatoia economy plus	39
118	Porta juta	56
118/P	Porta juta pieno	56
119	Mangiatoia Titti	45
122	Porta verdure e juta	46
123	Gancio fermafondo universale	125
124	Spazzolino Ø 16	91
124/A	Spazzolino Ø 50	91
124/B	Spazzolino Ø 40	91
124/C	Spazzolino Ø 75	91
125	Mangiatoia piccola g/plastica	41
126	Casetta per criceto	99
127	Mangiatoia pappagallo g/plastica	41
128	Beverino lungo lusso	24
129	Erogatore magic	29
130	Beverino magic	30
131	Sifone Marta	25
134	Sifone Firenze lusso	26
135	Altalena	89
138	Toilette Silvestro completa	109
142	Pinza universale	46
143	Ricambi sac. Snoopy 24 pz.	109
144	Mangiatoia criceto rotonda con base	101
146	Beverino per medicinali	23
147	Mangiatoia "lusso"	33
148	Comber-mangiatoia abbevert.	94
149	Comber-mangiatoia esterno	94
150	Maisonette	99
151	Maisonette lusso	99
152	Tartarughiera	105
153	Maisonette lusso vuota	99
154	Trappola per topi	101
155	Mangiatoia economy dispenser	39
156	Paletta igienica gatto	109
158	Beverino corto lusso	24
160	Mangiatoia Milano	33
162/18	Ciotola Lt. 1,5	111
162/20	Ciotola Lt. 1,2	111
162/24	Ciotola Lt. 3,5	111
162/26	Ciotola Lt. 6	111
162/T	Ciotola tripla	111
163	Tartarughiera Oasi	102
164	Tartarughiera Laguna	102
165	Portafieno	101
166	Anello con ventosa Ø 32 mm	101
167	Anello doppio con ventosa Ø 50 mm	101
169	Mangiatoia economy Diamant	39

CODICE	DESCRIZIONE	PAG
170	Beverino Aves	30
171	Beverino Aves	30
172	Mangiatoia Ines	41
173	Mangiatoia Dalia	41
174	Maisonette Baby	98
175	Tartarughiera Baby	104
176	Tartarughiera Elba	104
181	Nido Samsara completo estraibile Ø 10	49
182	Ciotola nido	51
183	Tartarughiera Maxi	102
184	Sifone Leo	23
185	Mangiatoia Hasselt	32
186	Porta	32
189	Trasportino Penelope	108
190	Mangiatoia Toledo	44
198	Tartarughiera Oasi maxi	98
199	Mangiatoia Piacenza	32
200	Trasportino con griglia fissa e mangiatoia esterna	7
201	Trasportino con griglia fissa e mangiatoia interna	8
202	Trasportino con griglia telescopica	9
203	Tino + n. 6 Secondino	12
204	Trasportino per ondulati a 5 posti	10
205	Trasportino per medie taglie a 5 posti	11
206	Beverino rettangolare	20
207	Coperchio con maniglia	7
208	Ruote	21
209	Divisoria per Tino	21
210	Gancio	20
211	Griglia per art. 200	22
212	Griglia per art. 201	22
213	Griglia per art. 202	22
214	Mangiatoia rettangolare	20
215	Parete estraibile per Tino	21
216	Posatoio per art. 200-201-202	20
217	Coperchio per Maxi Tino	11
218	Tino vuoto	8
219	Salva-goccia per art. 129	29
220	Trasportino singolo per taglie fino 14 cm	12
221	Beverino Secondino	24
222	Sifone universale	25
223	Nido completo estraibile Ø 8	49
224	Ciotola nido	51
225	Valigia completa di 10 Secondini	14
226	Valigia vuota	14
227	Parete estraibile per Maxi Tino	21

CODICE	DESCRIZIONE	PAG
228/A	Divisoria per Maxi Tino	21
228/C	Divisoria per Maxi Tino	21
229	Griglia per art. 204	22
230	Griglia per art. 205	22
232	Mangiatoia interna con ganci	33
233	Trasportino per trasporto collettivo retro chiuso	11
234	Maxi Tino + n. 10 Secondini	13
235	Tino Economy	6
236	Divisoria per Tino Economy	21
237	Supporti per secondino	21
238	Griglia per art. 235	22
239	Maxi Tino vuoto con supporti	13
240	Beverino Dino	24
242	Trasporto singolo per taglie fino 28 cm	19
244	Trasporto singolo per taglie fino 18 cm	15
245	Maxi Tino + n. 5 Secondini maxi	19
247	Gancio per coperchio valigia art. 225	20
248	Beverino Secondino maxi	20
249	Posatoio per art. 235	20
250	Interno completo x art. 200	7
251	Interno completo x art. 201	8
252	Interno completo x art. 202	9
253	Mangiatoia "Ara" piccola	31
254	Mangiatoia "Ara" media	31
255	Mangiatoia multipla	44
256	Valigia 6 posti per art. 244	15
257	Valigia 8 posti per art. 244	16
258	Valigia 12 posti per art. 244	16
259	Valigia 18 posti per art. 244	17
260	Carrello con 160 secondini medi	18
261	Valigia vuota 6 posti	15
262	Valigia vuota 8 posti	16
263	Valigia vuota 12 posti	16
264	Valigia vuota 18 posti	17
272	Posatoio plastica	90
273	Carrello con 60 secondini medi	18
273/A	Modulo superiore con 24 secondini	18
273/B	Modulo inferiore con 36 secondini	18
273/C	Comp. trasformazione ruote removibili	18
274	Sifone Aosta corto	23
275	Sifone Ferrara	25
276	Copertura x valigia 6 posti	15
277	Copertura x valigia 8 posti	16
278	Copertura x valigia 12 posti	16
279	Copertura x valigia 18 posti	17
280	Maisonette Candy	98

CODICE	DESCRIZIONE	PAG
281	Tartarughiera Daffy	102
283	Toilette Felix con cornice	109
284	Sifone Aosta lungo	23
285	Sifone Livorno	25
286	Trasportino Calipso	108
290/8	Fondello nido in vimini Ø 8	55
290/9	Fondello nido in vimini Ø 9	55
290/10	Fondello nido in vimini Ø 10	55
290/11	Fondello nido in vimini Ø 11	55
290/12	Fondello nido in vimini Ø 12	55
290/15	Fondello nido in vimini Ø 15	55
291	Fondello nido in juta Ø 8/10/12	54
292	Fondello nido in juta-cotone Ø 8/10/12	54
293	Fondello nido in poliestere Ø 10	54
294	Confezione di juta	56
295	Juta-cotone	56
296	Confezione di filo di cotone	56
297	Cocco-Sisal-Juta-Cotone	56
298	Cocco-Sisal-Meliga-Brattea	56
299	Nido goccia in vimini	54
300	Fibra di cotone per roditori	101
301	Tubo diam. int. 4 per art. 129	29
302	Tubo diam. int. 8 per art. 219	29
303	Raccordo a "T" per tubo art. 301	29
304	Uova medio Parrocchetto	59
305	Uova grandi Parrocchetto	59
306/MIX	Anelli in plastica multicolore Ø 3 mm	58
306/MONO	Anelli in plastica monocolori Ø 3 mm	58
307	Anelli "click" in plastica Ø 8/12/16	58
308	Anelli in alluminio Ø 2,5/3/4/6/8/10/12	58
309	Tronchese inox per anellini	58
310	Beverino Capri	30
311	Beverino Giglio	30
312	Tartarughiera Ischia	102
313	Mangiatoia Olanda c/ganci plastica	42
314	Mangiatoia Olanda c/ganci in ferro	42
315/B	Bandina Gabbia Espositore	83
315/C	Coperchio per gabbia esp. art. 315	83
315/F	Cassetto per gabbia esp. art. 315	83
315/G	Griglia per gabbia espos. art. 315	83
315/FB1	Gabbia espos. 1p. frontale bianco	80
315/FB3	Gabbia espos. 3p frontale bianco	81
315/FB3A	Gabbia espos. 3p frontale bianco	81
315/FN1	Gabbia espos. 1p. frontale nero	80
315/FN3V	Gabbia espos. verde 3p. frontale nero	81

CODICE	DESCRIZIONE	PAG
315/FN3	Gabbia espos. 3p. frontale nero	82
315/FZ3	Gabbia espos. 3 p. frontale zincato	82
315/SC	Gabbia espos. 3p. sistema carta	82
315/SP	Gabbia espos. c/foro laterale	80
315/T	Telaio per gabbia esposizione art. 315	83
317/B	Gabbia cova plastificata	61
317/Z	Gabbia cova zincata	61
318	Bagno esterno con ganci in plastica	47
320	Antispreco per art. 313/314	42
321	Sifone Bari	31
322	Porta sali Valencia	45
323	Mangiatoia eclissi	37
323/G	Gancio per attacco universale Mang.Eclissi	38
323/I	Supporti attacco interno gabbia Mang. Eclissi	38
324	Mangiatoia per svezamento	42
325	Nido medio	50
326/B	Gabbia cova	62
326/Z	Gabbia cova zincata	62
326/SC	Gabbia cova	63
327	Laterale in plastica per gabbia cova 58	64
328	Cassetto per gabbia cova 58	64
330	Guida per divisorio	65
331	Divisorio chiuso per gabbia cova 58	65
332	Griglia per gabbia cova 58	65
333	Griglia incurvata per gabbia cova 58	65
334	Gancio ferma griglia	64
335	Mangiatoia Amsterdam	32
336	Coperchio per mangiatoia mezzaluna	34
337	Sistema voliera	64
338	Rubinetto per tubo art. 301	29
339	Serbatoio per impianto a goccia	29
340	Struttura per sistema carta 2X4	75
341	Struttura per sistema carta 4X4	75
342	Struttura per sistema cassetto 2X4	76
343	Struttura per sistema cassetto 4X4	76
344	Ruota per struttura singola art. 340/342	81
345	Struttura doppia per sistema carta 2X4	77
346	Struttura doppia per sistema carta 4X4	77
347	Struttura doppia per sistema cassetto 2X4	78
348	Struttura doppia per sistema cassetto 4X4	78
349	Rotolo di carta 12X33	79
350	Posatoio per gabbia da cova	65
351	Struttura per sistema carta 4X5	84
352	Struttura per sistema cassetto 4X5	85
353	Ruote per struttura singola	85
354	Rotolo di carta 10X18	84

CODICE	DESCRIZIONE	PAG
355	Posatoio Sunset	91
356	Gancio per unione gabbia cm 58	64
357	Ciotola Minou Lt.0,2	110
358	Ciotola Bizet Lt. 0,3	110
359	Ciotola Matisse Lt. 0,5	110
360	Ciotola doppia Romeo Lt. 0,3x2	110
361	Sifone Revolution cc 72	28
362	Sifone Revolution cc 105	28
363	Sifone Revolution cc 140	28
364	Sifone Revolution cc 200	28
365	Sifone Revolution cc 260	28
366	Sifone Revolution cc 400	28
370	Maisonette Cleo	98
371	Tartarughiera Toby	103
372	Tartarughiera Sammy	103
374	Nido Paradise	52
375	Parete retro per gabbia cova cm 58	63
376	Nido Interno in plastica Relax Ø 10	51
377	Gabbia cantori da esposizione	87
379	Scheda cova per nido 181/223	49
380	Sifone Amalfi	25
381	Nido in gommapiuma Ø 10	51
382	Fondello in gommapiuma Ø 12	51
383	Griglia per gabbie 20/21/288	86
384	Porta-scheda Twister	57
385	Schedina Twister	58
386	Sifone Venezia	23
387	Sifone Pisa	23
388	Portina in ferro con molla	89
389	Sifone Ghiotto con ventose cc 70	100
390	Sifone Bijou cc 90	100
391	Sifone Jingle con anello cc 200	100
392	Sifone Elliot con ventose cc 200	100
393	Sifone Elvis con anello cc 400	100
394	Portanido in ferro Ø 8	51
395	Anello per beverini cc 400	27
396	Cassetto gabbia cova 120	71
397	Laterale in plastica per gabbia cova 90 e 120	71
398	Kit voliera gabbia cova 90 e 120	72
399	Parete retro per gabbia 120	72
400	Gabbia cova 120 Cortina	69
401	Gabbia cova 120 Bormio	69
402	Gabbia cova 120 Sestriere	70
403	Gabbia cova 120 Livigno	70
404	Griglia bianca per gabbia cova 120	71
405	Griglia zincata per gabbia cova 120	71

CODICE	DESCRIZIONE	PAG
407	Posatoio con perno per gabbia 90 e 120	73
408	Posatoio per gabbia 90 e 120	73
409	Maniglia universale	73
410	Porta mangiatoia interno	73
411	Divisorio in plastica per cova 90 e 120	71
413	Divisorio in ferro per cova 90 e 120	72
414	Cassetto gabbia cova 90	71
416	Parete retro per gabbia cova 90	74
417	Kit guide per gabbia cova 90	74
418	Carrello 120 per gabbie cova	74
419	Carrello 180 per gabbie cova	74
420	Gabbia cova 90 Positano	68
421	Gabbia cova 90 Portofino	68
423	Griglia bianca per gabbia cova 90	71
424	Carta bulinata per cova 58	65
425	Carta bulinata per cova 120	73
426	Carta bulinata per cova 90	73
427	Nido Agapornis	53
427T	Coperchio per nido Agapornis	53
428	Valigia 8 posti verde	87
429	Carrello 90 per gabbie cova	74
430	Mangiatoia componibile Recupera	35
432	Nido per esotico	54
432/G	Ganci per nido esotico	54
433	Mangiatoia Unika	36
435	Bagnetto Esterno Garda	47
437	Easy Nest	49
438 B	Bagno esterno Como	48
438 T	Bagno esterno Como	48
440	Portamedicinali Vitality	46
441 T	Bagno esterno Braies	48

CODICE	DESCRIZIONE	PAG
441 W	Bagno esterno Braies	48
442	Divisorio in plastica grigliato	71
443	Gabbia trasportino Brooklin	86
444	Gabbia trasportino Manhattan	86
445	Gabbia New York	86
446	Griglia per gabbia 443 - 444 - 445	86
450	Mangiatoia per semi kiku	95
451	Mangiatoia per palle di grasso Ume	95
454	Carrello 58 per gabbia cova	79
455	Carrello 60 per gabbia cova	74
458	Maxi Tino griglia telescopica	10
460	Gabbia cova 60 Taormina	66
461	Gabbia cova 60 Tropea	66
462	Gabbia cova 60 Porto Cervo	67
463	Gabbia cova 60 Polignano	67



2 GR di Gobbi Luciano & C. snc
Via Verzelloni, 14 - 42015 Correggio (RE) - Italy
Tel. +39.0522.694935
www.2g-r.com - info@2g-r.com

